

CONTACTORS

Type **BMS36.10**

RAIL VEHICLES / FIXED INSTALLATION

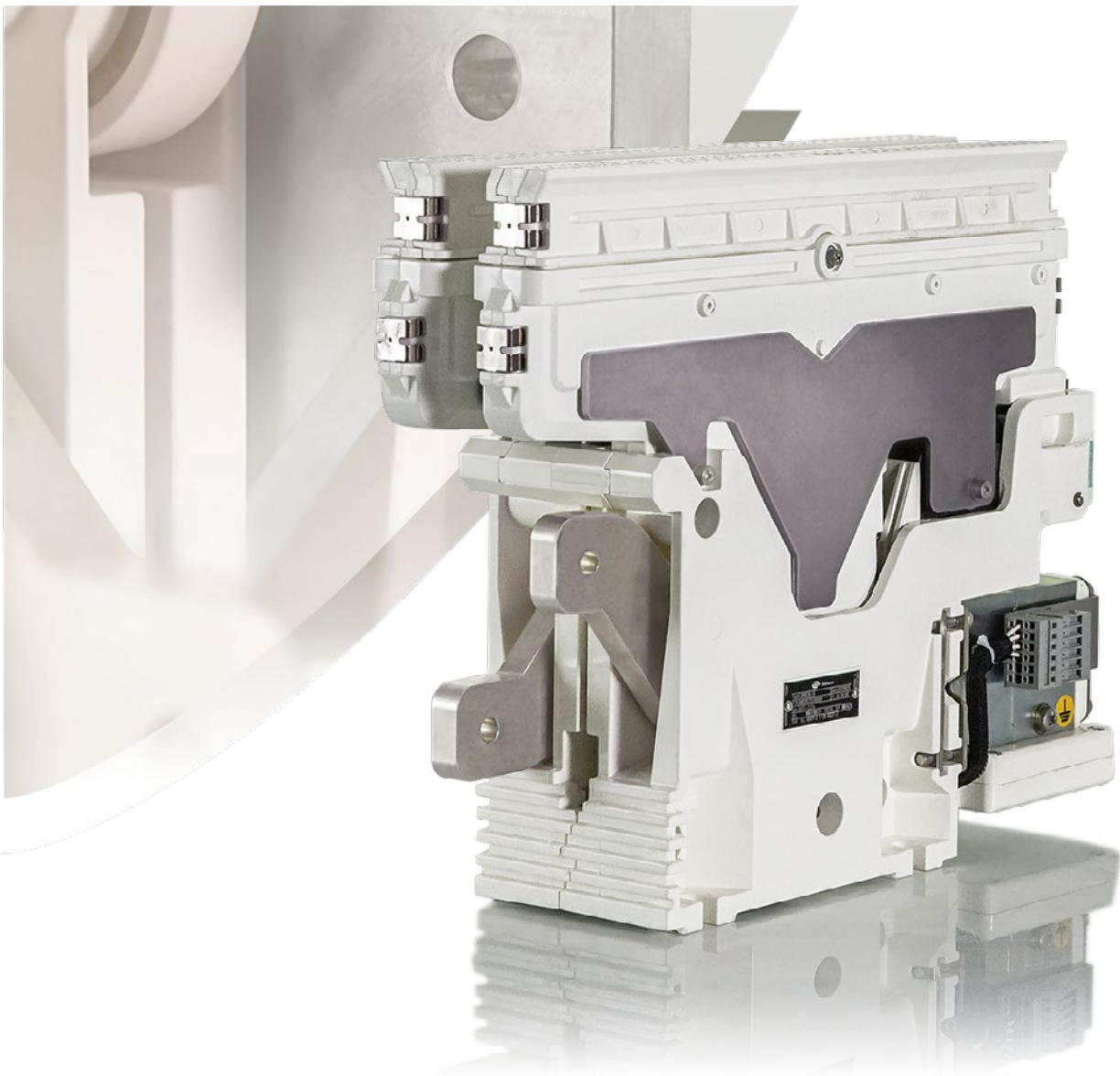

GENERAL INFORMATION

The **BMS** contactor, with its outstanding track record, is a contactor valued by the car builders and operators of electric traction vehicles for its strong performance level and its extremely high reliability. Taking advantages of its recognized features and design, Sécheron has developed a new BMS36 range suitable for 3 kV_{DC} rail vehicles as well as for the 25 kV_{AC} rail vehicles with intermediate DC-bus voltage up to 4,000 V_{DC}. With the first configuration BMS36.10 released to the market, Sécheron shows once again its strong competencies to master 3 kV switching devices, bringing multiple key benefits to car builders and operators using it.

Combining a compact size with a light weight, it is particularly efficient to interrupting low currents while offering also the highest breaking capacity in its category. Particular care has been taken to make the integration of the contactor in the car builder's line breaker box or converter unit the friendliest. Designed with high insulation performances to match installation in the most severe indoor environmental conditions, the BMS36.10 offers also the most compact installation volume thanks to its unique arc chute. The BMS36.10 contactor is the ideal solution to be used with our high-speed DC circuit breakers type UR26-64 or our AC vacuum circuit breakers type MACS.

APPLICATIONS, TYPICAL EXAMPLES

- Line contactors for DC vehicles.

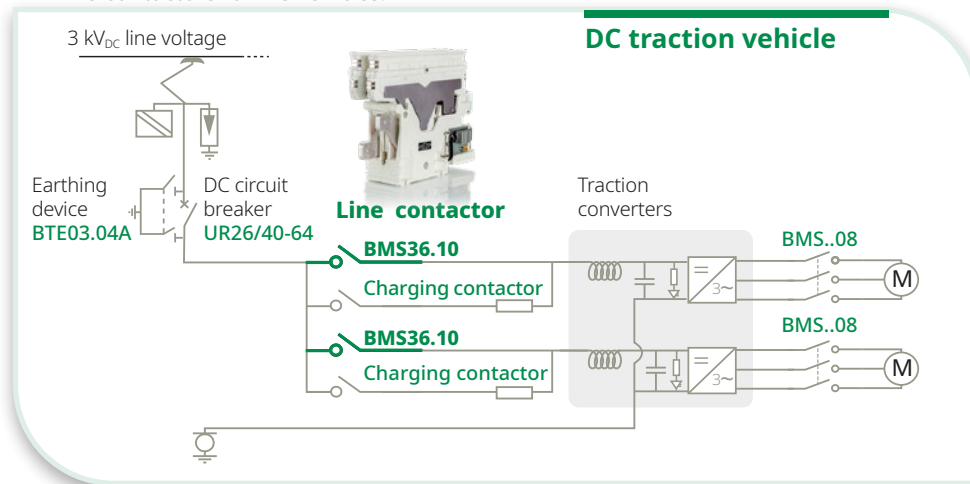

- Separation/line contactors for AC vehicles.

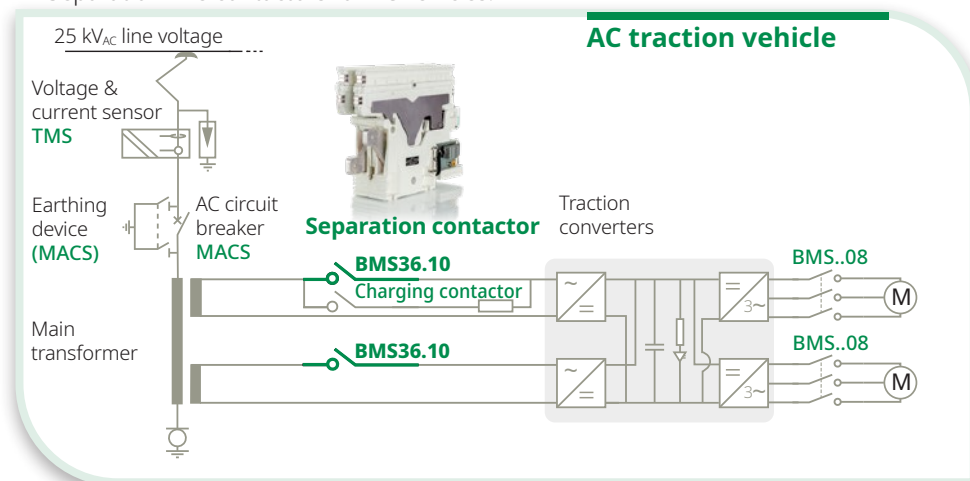

- Contactors for DC traction power substations and other industrial fields.

MAIN FEATURES

- Normally open and bidirectional contactor.
- Rated voltage 3,600 V_{DC/AC}.
- Conventional free air thermal current 1,000 A.
- Available in 1 pole configuration.
- Low voltage control coil protection against surges.
- Suitable for ambient temperature from -40°C to +70°C.
- Reference standards: EN/IEC 60077-1/-2, EN/IEC 61373, EN 45545, EN 50657.

MAIN BENEFITS

- ✓ No critical current.
- ✓ Very compact and low weight.
- ✓ Highest insulation level for indoor installation.
- ✓ Designed for optimal integration in line breaker and converter boxes.
- ✓ Reduced insulation distances for installation.
- ✓ High mechanical and electrical durability.
- ✓ Pollution degree PD3A.
- ✓ Convenient and safe interfacing with HV connections (rear side) & LV circuits (front side).
- ✓ Horizontal or vertical mounting to match vehicle's installation constraints.
- ✓ Low maintenance requirements with easy access to the main contacts for replacement.
- ✓ Worldwide proven design.

APPLICATIONS

DC typical application

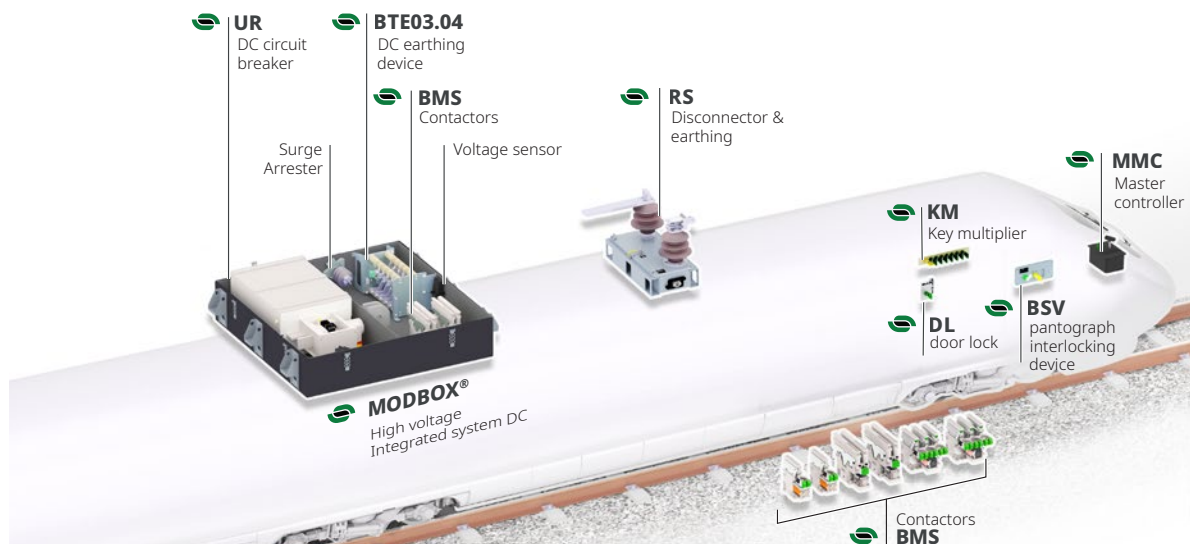

AC typical application

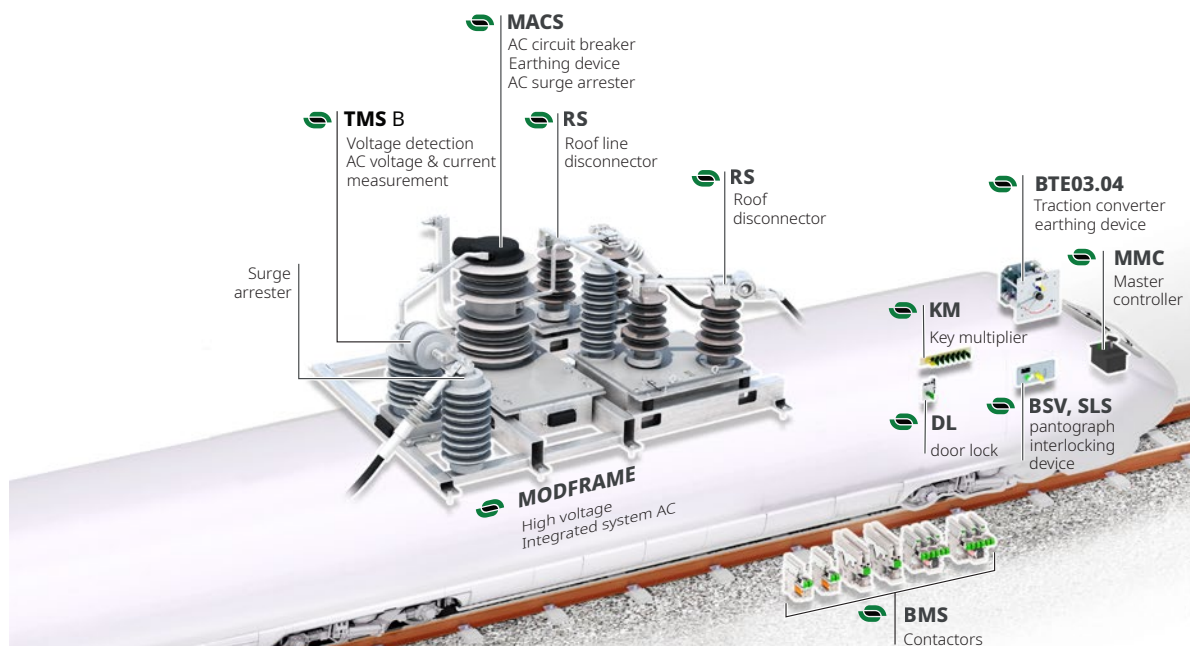

DATA FOR PRODUCT SELECTION

Symbol		Unit	BMS 36.10
MAIN HIGH VOLTAGE CIRCUIT			
Pole quantity			1
Component category			A2
Type of main contact			Normally Open
Rated operational voltage		[V]	
- DC voltage	U_r	[V]	3,600
- AC voltage (16.7, 25, 50/60)	U_r	[V]	3,600
Rated insulation voltage	U_{Nm}	[V _{DC}]	4,800
		[V _{AC}]	4,800
Conventional free air thermal current ⁽²⁾	I_{th}	[A]	
- DC voltage & AC voltage (16.7, 25, 50/60 Hz)			1,000
Rated operational current/operational frequency			
- DC voltage	I_r	[A]	400 (C3), 500 (C2); 800 (C1)
- AC voltage	I_r	[A]	1,000 / C2
Maximum breaking capacity			
- DC current, $\tau = 15$ ms	I_{bc}	[A]	3,000
- AC current, $\cos \Phi = 0.8$ (16.7, 25 & 50/60 Hz)	I_{bc}	[A]	3,000
Maximum making capacity			
- DC current, $\tau = 15$ ms	I_{mc}	[A]	3,000
- AC current, $\cos \Phi = 0.8$ (16.7, 25 & 50/60 Hz)	I_{bc}	[A]	3,000
Rated short-time withstand current	$I_{cw/t}$	[kA]/[ms]	10 / 100
Peak short-time withstand current	\hat{I}_{cw}	[kA]	10
Rated power-frequency withstand voltage (50 Hz/1min)	U_a	[kV _{AC}]	11.5
Rated impulse withstand voltage	U_{Ni}	[kV]	25
⁽¹⁾ At $T_{amb} = +40^\circ\text{C}$ and tested with HV connections with current density 1.7 A/mm ² .			
LOW VOLTAGE CIRCUIT			
Control circuit			
Nominal supply voltage ⁽⁴⁾	U_n	[V _{DC}]	24 to 110
Nominal control voltage ⁽⁴⁾	U_{EF}	[V _{DC}]	24 to 110
Range of voltage			[0.7 - 1.25] U_n
Nominal closing power ⁽⁴⁾⁽⁵⁾	P_c	[W]	≤ 60
Nominal holding power ⁽⁴⁾⁽⁵⁾	P_h	[W]	≤ 4
Typical mechanical closing time ⁽⁵⁾	t_{cc}	[ms]	110 to 130
Typical mechanical opening time ⁽⁵⁾	t_{co}	[ms]	50 to 60
⁽⁴⁾ For detailed values based on BMS configuration, please refer to page 9 • ⁽⁵⁾ At U_n and $T_{amb} = +20^\circ\text{C}$.			
Auxiliary contacts			
Type of contacts			Potential free (PF)
Rated voltage		[V _{DC}]	24 to 110
Conventional thermal current	I_{th}	[A]	10
Utilization category according to EN60947			
- AC-15 230 V _{AC}			1.0 A
- DC-13 110 V _{DC}			0.5 A
Minimum let-through current at 24 V _{DC} ⁽⁶⁾		[mA]	≥ 10 (silver contacts) or $4 \leq I < 10$ (gold contacts)
⁽⁶⁾ For a dry and clean environment.			
Low voltage interface			
Control circuits			Wago terminal
Auxiliary switches			Direct on switches
Insulation			
Rated power-frequency withstand voltage (50 Hz / 1min)			
- LV circuit to earth	U_a	[kV]	1.5
OPERATING CONDITIONS			
Installation			Indoor
Altitude		[m]	$\leq 2,000$
Working ambient temperature	T_{amb}	[°C]	- 40 to + 70
Humidity			95% at + 40°C
Pollution degree			PD3A
Minimum mechanical durability	N	Cycles	2 millions

PRODUCT INTEGRATION

MAIN DIMENSIONS

HV connections	M10 screws
Earth connections	M6 screws, thread length 8 mm
LV Connections	BMS control: Wago terminal BMS auxiliary switches: M3 screws
Fixing points	M8 screws

Dimensions without tolerances are indicative. All dimensions are in mm. The maximum allowed flatness deviation of the support frame is 0.5 mm.

BMS36.10

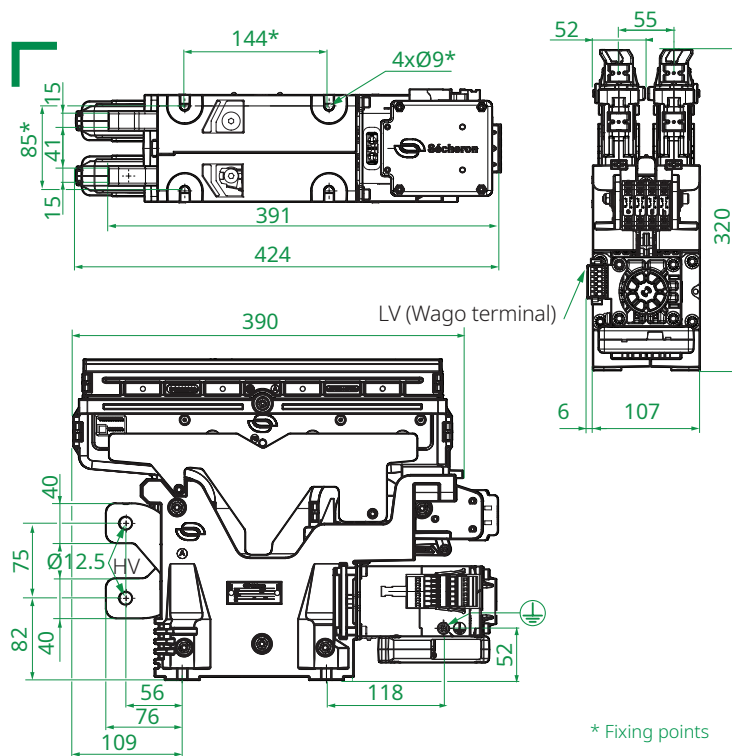

BMS36.10

1-POLE
Horizontal/vertical
installation

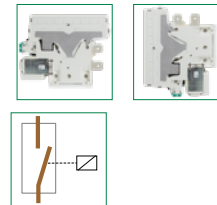

* Fixing points

INSULATION DISTANCES AND WEIGHTS

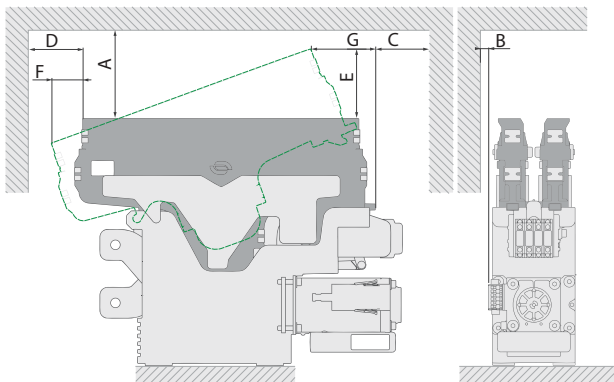

BMS contactors have been homologated according to IEC 60077-2 with the following insulation distances.

contactor type	Breaking current	Arc chute type	Insulating distance [mm]								Arc chute removal distance [mm]			Weight: ± 1 kg [kg]
			To earthed wall				To insulating wall				E	F	G	
			A	B	C	D	A	B	C	D				
BMS36.10	≤ 800	A	30	40	50	75	30	30	50	75	90	40	80	1 Pole 16
	> 800		50	50	75	100	40	40	75	100				

AUXILIARY CONTACTS CONFIGURATION

BMS36.10

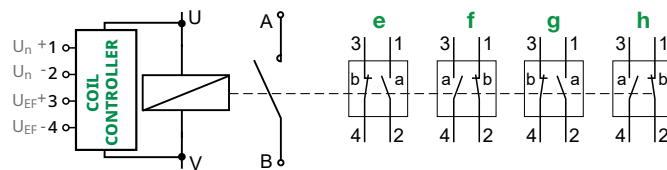
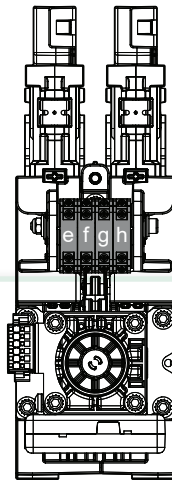

LOW VOLTAGE CONTROL DIAGRAM

BMS CONFIGURATION	Nominal supply voltage ⁽¹⁾ U_n [V _{DC}]	Nominal control voltage ⁽¹⁾ U_{EF} [V _{DC}]	Closing power (P_c) / Holding power (P_h) [W] / [W]
BMS36.10 horizontal / vertical installation	1 pole [24-36], [48-110]	[24-110]	≤ 60 / ≤ 4

⁽¹⁾ Control voltage U_{EF} and supply voltage U_n can be different.

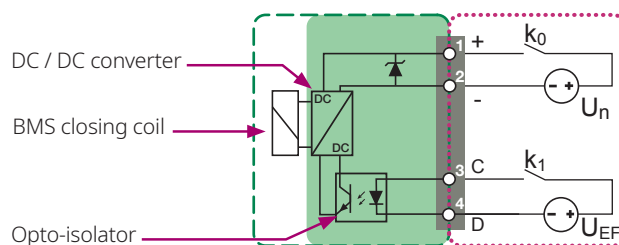

CONTROL TYPE Coil controller

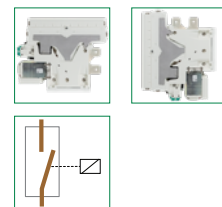

--- Sécheron's scope
 Customer's scope

Low voltage interface
 Coil controller

U_n : DC power supply
 U_{EF} : Control voltage
 k_0 : Supply relay
 k_1 : Control relay

SECHERON CONTACTORS RANGE

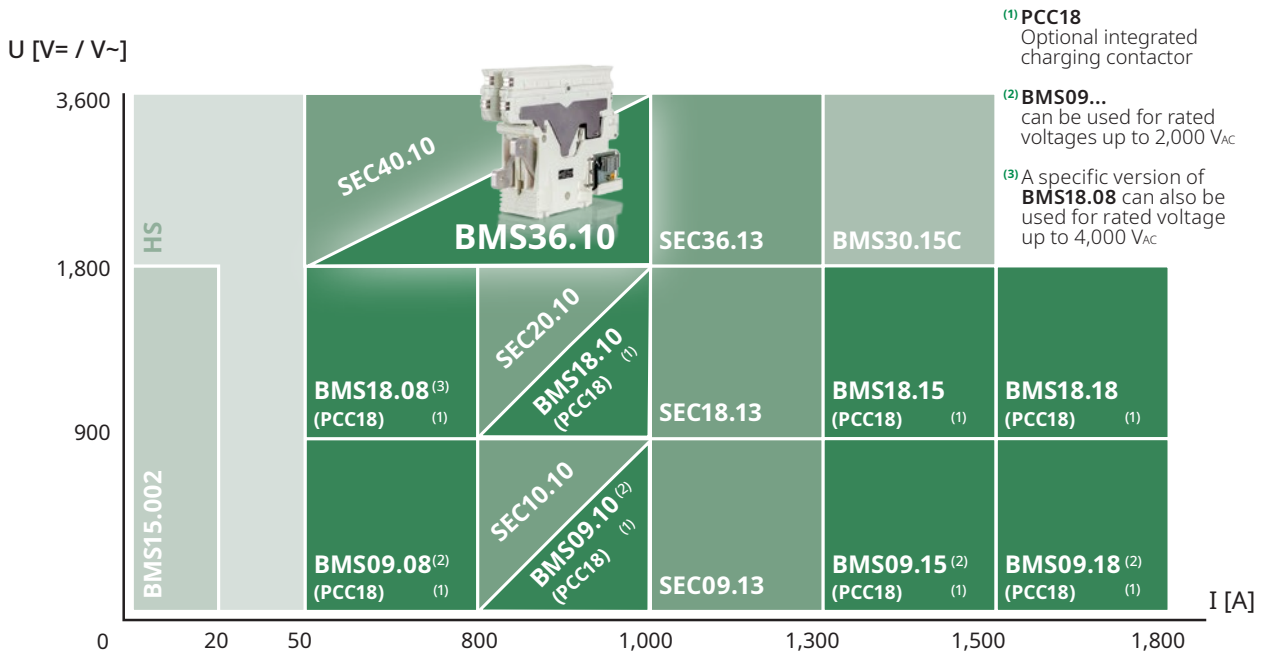

AT A GLANCE

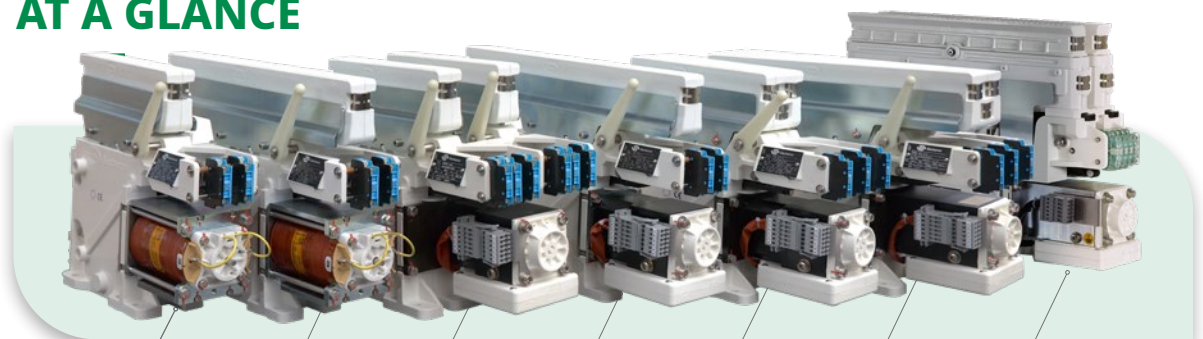

BMS 09.08

1 pole
Arc chute
Type A

BMS 18.08

1 pole
Arc chute
Type A

BMS 09.08

2 poles
Arc chute
Type A

BMS 18.10

1 pole
Arc chute
Type A

BMS 09.15

1 pole
Arc chute
Type A

BMS 18.18

1 pole
Arc chute
Type A

BMS 36.10

1 pole

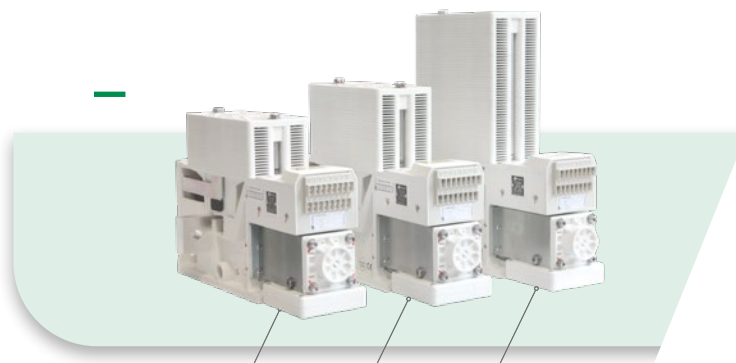

SEC10.10/
SEC09.13

SEC20.10/
SEC18.13

SEC40.10/
SEC36.13

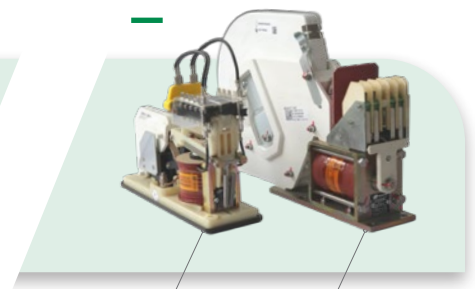

BMS15.002

HSB

DESIGNATION CODE FOR ORDERING

- Be sure to establish the designation code from the latest version of our brochure by downloading it from the website: www.secheron.com.
- Be careful to write down the complete alphanumerical designation code with 16 characters when placing your order.
- For technical reasons some variants and options indicated in the designation code might not be combined, therefore validate your configuration with Sécheron before ordering.
- For other configurations not described in the brochure, please contact Sécheron.

Example of customer's choice:	BMS	36	10	Z	1	Z	Z	E	A	Z	V	D
Line:	10	11	12	13	14	15	16	17	18	19	20	21

The bold characters of the designation code define the device type.

Note: some combinations may not be possible, therefore validate your configuration with Sécheron before ordering

DESIGNATION CODE

Line	Description	Designation		Customer's
		Standard	Options	choice
10	Product type BMS	BMS	BMS	BMS
11	Rated operational voltage	3,600 V	36	36
12	Rated conventional free air thermal current	1,000 A	10	10
13	Spare digit		Z	
14	Number of poles	1 pole	1	
15	Spare digit		Z	
16	Spare digit		Z	
17	Nominal supply voltage	24 V _{DC} 36 V _{DC} 48 V _{DC} 72 V _{DC} 110 V _{DC}	A B C D E	
18	Auxiliary contacts BMS	1a + 1b - (switch PF) - silver type 1a + 1b - (switch PF) - gold type 2a + 2b - (switch PF) - silver type 2a + 2b - (switch PF) - gold type 3a + 3b - (switch PF) - silver type 3a + 3b - (switch PF) - gold type 4a + 4b - (switch PF) - silver type 4a + 4b - (switch PF) - gold type	A	C E H K M O P
19	Spare digit		Z	
20	Installation configuration	Horizontal & Vertical	V	
21	Application type	(Direct Current) DC (Alternating Current) AC	D	A

Signature:

Name:

Place and date:



Sécheron SA
Rue du Pré-Bouvier 25
1242 Satigny - Geneva
CH-Switzerland

www.secheron.com
Tel: +41 22 739 41 11
Fax: +41 22 739 48 11
ess@secheron.com

SA015795BEN_A04-05.24