

CONTACTORS

Type **BMS18.01 & BMS36.01**
Unidirectional contactors

ELECTRIC TRANSPORT VEHICLES / FIXED INSTALLATIONS



GENERAL INFORMATION

The **BMS18.01** and **BMS36.01**, with a thermal current of 100 A and rated voltage up to 1.8 kV_{DC} or 3.6 kV_{DC} respectively, have been designed to cover multiple applications on electric transport vehicles, but also in fixed installations.

For rail vehicles, this series of contactors, depending on the chosen configuration, Normally Open or Normally Closed, is used to precharge or discharge the input filter capacitors of traction and auxiliary power inverters, and as a line contactor for auxiliary power inverters. When used as precharging contactor, the BMS...01 series, with its narrow width and adjusted height, can be easily combined with our other BMS09.../

BMS18.../BMS36- range. Both, the precharging and line contactors can be supplied separately, or as an assembled module, with or without the precharging resistor, ready for horizontal or vertical installation.

For fixed installations (DC power supply in public transport and railway networks), the BMS...01 series is used as contactors for line testing prior to closing the line/feeder breakers.

Designed and extensively tested to ensure high performance and reliability, this BMS...01 series requires a small volume for integration and offers an easy access for installation and wiring.

APPLICATIONS, TYPICAL EXAMPLES

Transport vehicles

DC rail vehicles applications

Precharging contactor - typical scheme

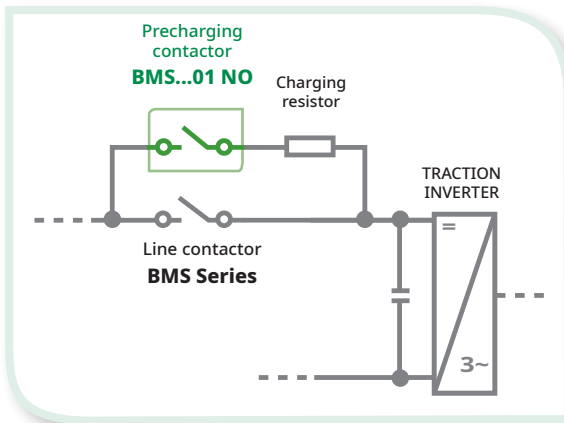

Line contactor - typical scheme

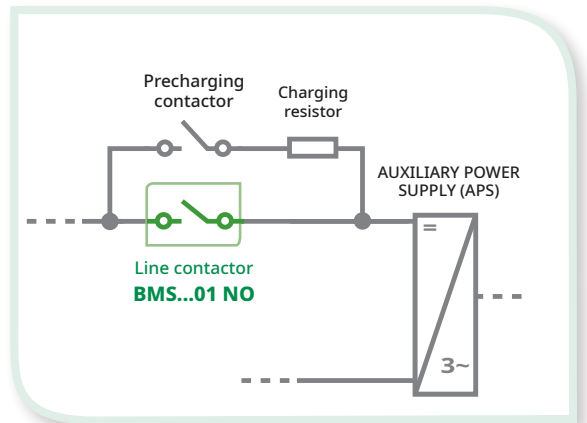

Discharging contactor - typical scheme

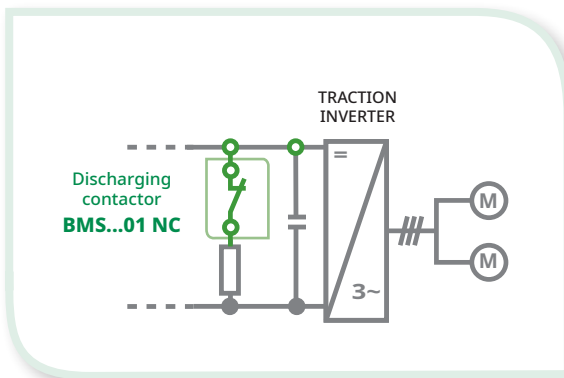

Fixed installation

Line test contactor - typical scheme

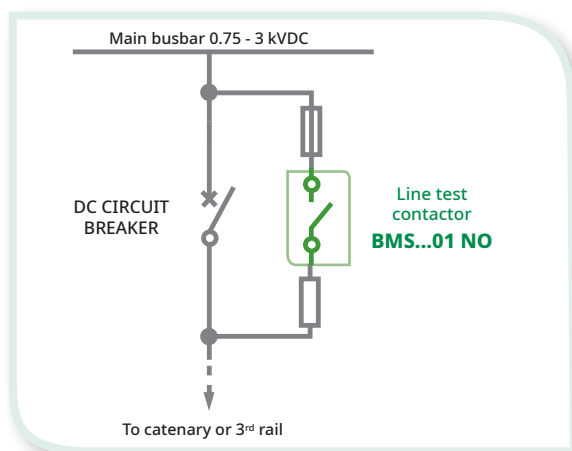

MAIN FEATURES

- Normally Open (NO) or Normally Close (NC) configuration.
- Unidirectional polarized for DC.
- Rated voltage 1,800 V_{DC} or 3,600 V_{DC}.
- Conventional free air thermal current 100 A at 70°C.
- Available in 1 pole configuration.
- Low voltage control coil protection against surges.
- Suitable for ambient temperature from -40°C to +70°C.
- Reference standards: EN/IEC 60077-1/-2, EN/IEC 61373, EN 45545.

MAIN BENEFITS

- ✓ No critical current.
- ✓ High insulation level and resistance against pollution PD3A.
- ✓ Compact size for effective integration with BMS line contactors.
- ✓ Reduced insulation clearances required for installation.
- ✓ High mechanical and electrical durability.
- ✓ Horizontal or vertical mounting to match vehicle's installation constraints.
- ✓ Designed for maintenance free operation.

DATA FOR PRODUCT SELECTION

Symbol	Unit	BMS18.01	BMS36.01
MAIN HIGH VOLTAGE CIRCUIT			
Pole quantity		1	
Component category		A2	
Type of main contacts		NO Normally Open	NC Normally Closed
Polarity		Unidirectional	
Current interruption direction		Unidirection DC (polarized)	
Rated operational voltage	U_r [V _{DC}]		
- DC voltage		1,800	3,600
Rated insulation voltage	U_{Nm} [V _{DC}]	2,300	4,800
Overvoltage category		OV3	
Conventional free air thermal current ⁽¹⁾	I_{th} [A]	100 (T _{amb} =+70°C)	
Rated operational current/operational frequency	I_r [A]		
- DC current, $\tau=1$ ms		100/C1	
Short-circuit making and beaking capacity ⁽¹⁾	I_{bc} / I_{mc} [A]	150	120
Critical currents	[A]	No critical current	
Current interruption direction		Unidirection DC (polarized)	
Rated short-time withstand current	$I_{cw/t}$ [kA]/[ms]		
- DC current		3 / 100	1/100
Power-frequency test voltage (50 Hz / 1min)	U_a [kV]	6.9	11.5
Rated impulse withstand voltage	U_{Ni} [kV]	15	25
⁽¹⁾ 100 A at T= 1 ms.			
LOW VOLTAGE CIRCUIT			
Control circuit			
Nominal supply voltage	U_n [V _{DC}]	24; 32; 36; 48; 72; 84; 96 or 110 ⁽²⁾	
Range of voltage		[0.7 - 1.25] U_n	
Typical mechanical closing time ⁽³⁾	t_{cc} [ms]	30	60
Typical mechanical opening time ⁽³⁾	t_{co} [ms]	100	60
⁽²⁾ For other voltage, please contact sécheron. ⁽³⁾ At U_n and T _{amb} = +20°C.			
Auxiliary contacts			
Type of contacts		Dual break type (DB) or Changeover type (CO)	
Rated voltage	[V _{DC}]	24 to 110	
Conventional thermal current	I_{th} [A]	6 or 10 depending from the version	
Utilization category according to EN60947 for Dual break type (DB) - DC-13 110 V _{DC}		0.5 A	0.5 A
for Changeover type (CO) - DC-13 60 V _{DC} - DC-13 24 V _{DC}		0.5 A 2.0 A	0.5 A 2.0 A
Minimum let-through current at 24 V _{DC} ⁽³⁾	[mA]	≥ 10 (silver contacts)	
⁽³⁾ For a dry and clean environment.			
Low voltage interface			
Control circuits		Wago 294 terminal (standard) / Cage clamp 10-pole connector (option)	
Auxiliary switches		Direct connection (standard) Cage clamp 10-pole connector (option)	
Insulation			
Power-frequency test voltage (50 Hz / 1min)	U_a [kV]	1.5	
OPERATING CONDITIONS			
Installation		Indoor	
Altitude	[m]	≤ 2,000	
Working ambient temperature	T _{amb} [°C]	-40 to +70	
Humidity		95% at + 40°C	
Pollution degree		PD3A	
Minimum mechanical durability	N Operations	≥ 2 millions	

PRODUCT INTEGRATION

MAIN DIMENSIONS

HV connections	M5 screws
Earth connections	M5 screw
LV Connections (standard)	BMS control: screw terminal ⁽¹⁾ BMS auxiliary switches: M3 screws
Fixing points	M6 screws

Dimensions without tolerances are indicative. All dimensions are in mm. The maximum allowed flatness deviation of the support frame is 0.5 mm.

⁽¹⁾ Integrated 10-pole connector available as option

/// BMS18.01 NO / BMS18.01 NC

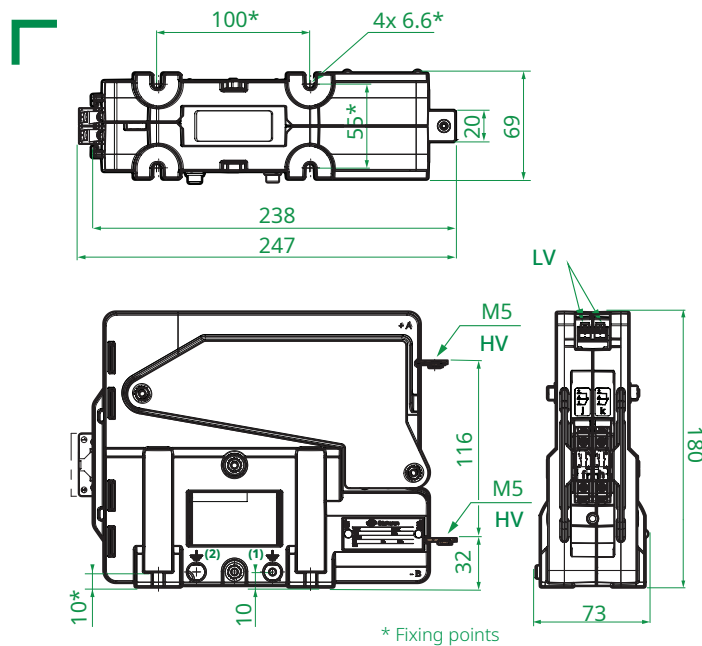

BMS18.01 NO / NC

1-POLE
Horizontal/vertical installation

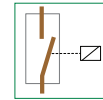

Weight: 4 ±1 kg

⁽¹⁾ Ground terminal for Normally Open configuration

⁽²⁾ Ground terminal for Normally Closed configuration

/// BMS36.01 NO / BMS36.01 NC

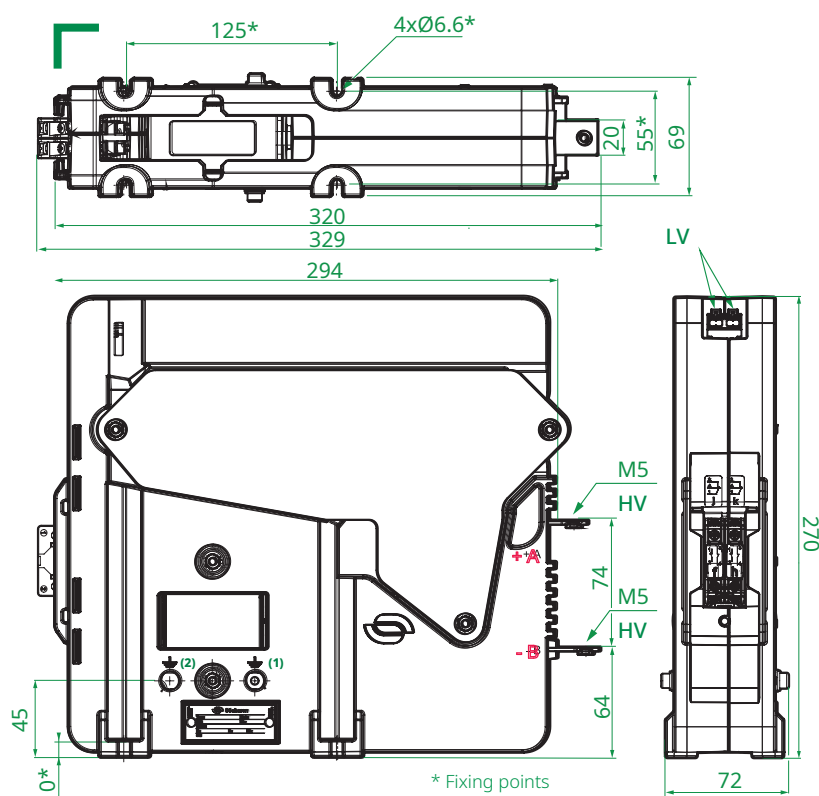

BMS36.01 NO / NC

1-POLE
Horizontal/vertical installation

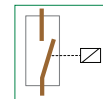

Weight: 6 ±1 kg

⁽¹⁾ Ground terminal for Normally Open configuration

⁽²⁾ Ground terminal for Normally Closed configuration

INSULATION DISTANCES

/// BMS18.01 NO / BMS18.01 NC

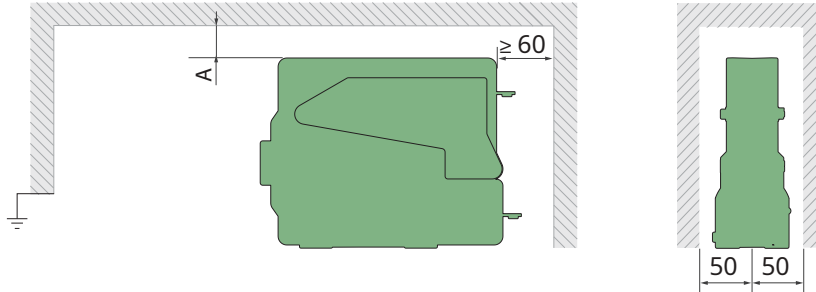

Value given for the maximum breaking capacity (150 A). For lower breaking current distance can be reduced. Please contact Sécheron.

Breaking current	Arc chute removal distance [mm]
	A
≤ 100 A	70
< 40 A	35
< 20 A	20

/// BMS36.01 NO / BMS36.01 NC

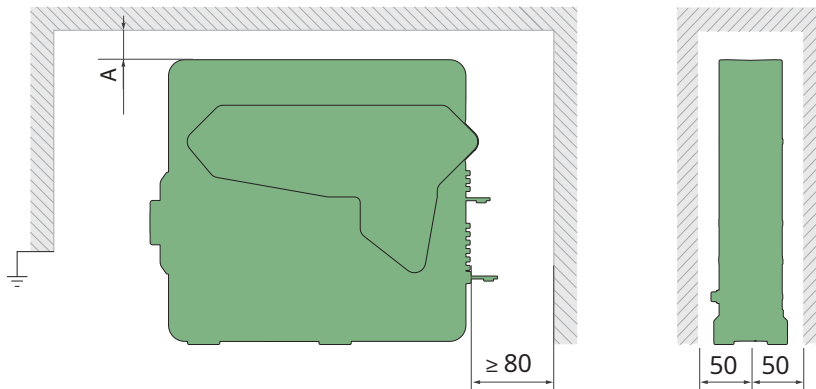

Breaking current	Arc chute removal distance [mm]
	A
≤ 100 A	30
< 70 A	20

AUXILIARY CONTACTS CONFIGURATION

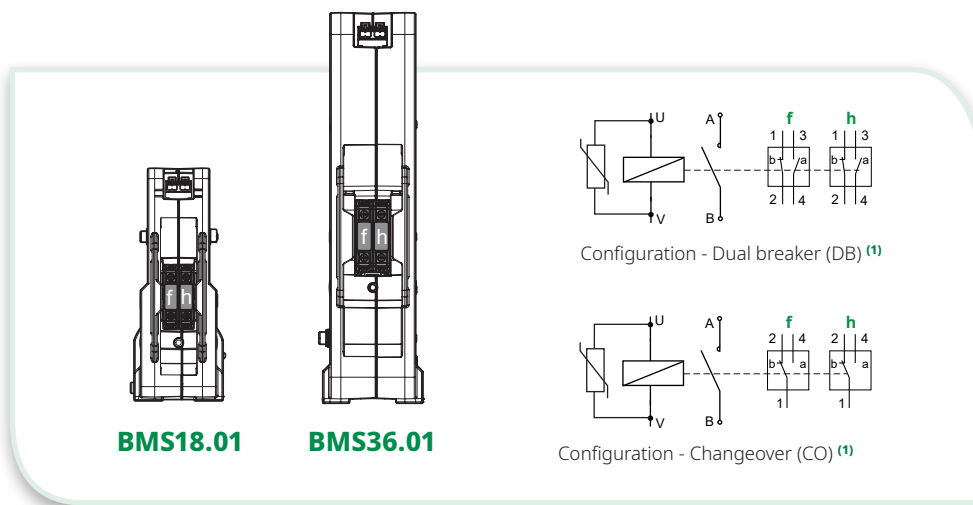

⁽¹⁾ For other available possibilities, please contact sécheron

SECHERON CONTACTORS RANGE

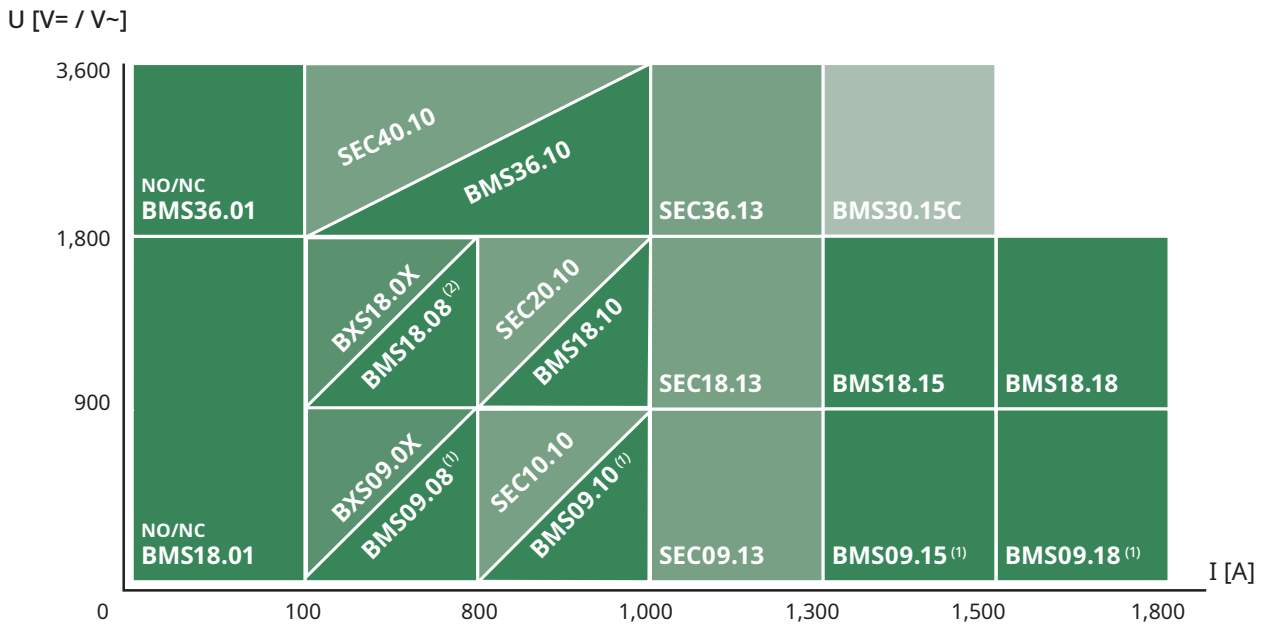

BMS15.002 and HS contactors are still available on request for delivery for repeat order or as spares.

⁽¹⁾ BMS09... can be used for rated voltages up to 2,000 V_{AC}

⁽²⁾ A specific version of BMS18.08 can also be used for rated voltage up to 4,000 V_{AC}

AT A GLANCE

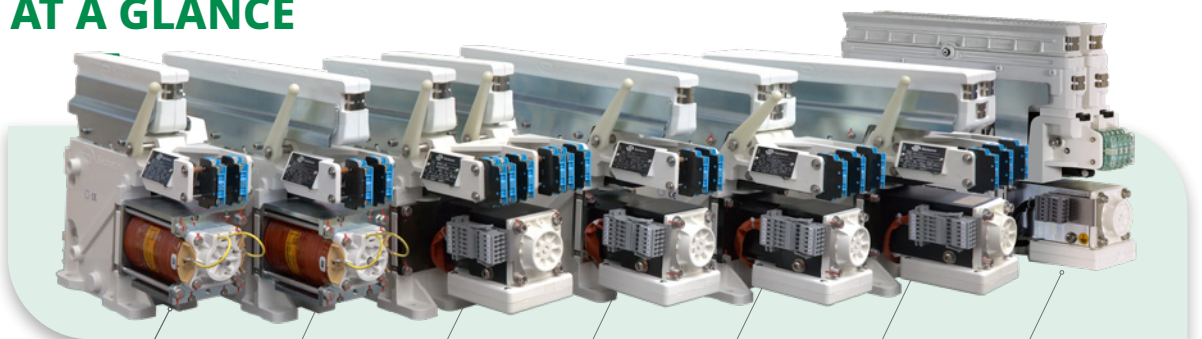

BMS 09.08

1 pole
Arc chute
Type A

BMS 18.08

1 pole
Arc chute
Type A

BMS 09.08

2 poles
Arc chute
Type A

BMS 18.10

1 pole
Arc chute
Type A

BMS 09.15

1 pole
Arc chute
Type A

BMS 18.18

1 pole
Arc chute
Type A

BMS 36.10

1 pole

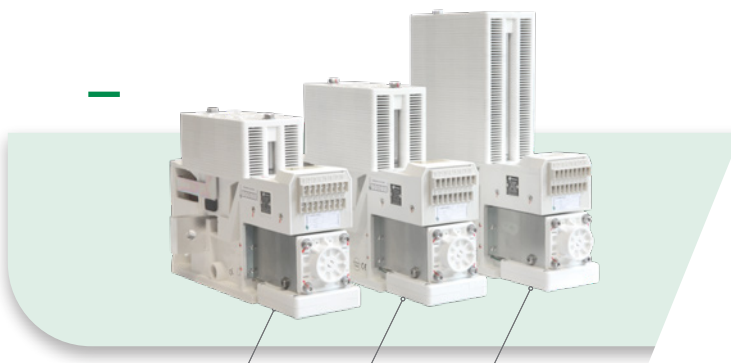

SEC10.10/
SEC09.13

SEC20.10/
SEC18.13

SEC40.10/
SEC36.13

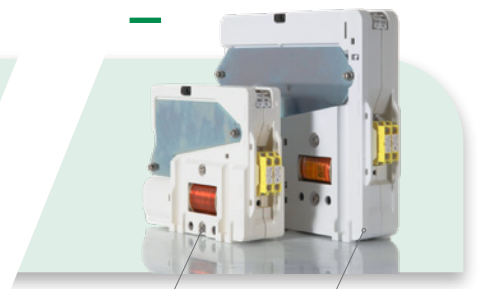

BMS18.01

BMS36.01

DESIGNATION CODE FOR ORDERING

- Be sure to establish the designation code from the latest version of our brochure by downloading it from the website: www.secheron.com.
- Be careful to write down the complete alphanumeric designation code with 15 characters when placing your order.
- For technical reasons some variants and options indicated in the designation code might not be combined, therefore validate your configuration with Sécheron before ordering.
- For other configurations not described in the brochure, please contact Sécheron.

Example of customer's choice:	BMS	18	01	O	1	A	A1	A	A	A
Line:	10	11	12	13	14	15	16	17	18	19

The bold characters of the designation code define the device type.

DESIGNATION CODE

Line	Description	Designation		Customer's
		Standard	Options	choice
10	Product type	BMS	BMS	BMS
11	Rated operational voltage	1,800 V	18	
		3,600 V	36	
12	Rated conventional free air thermal current	100 A	01	01
13	Main contact configuration	Normally Open	O	
		Normally Closed	C	
14	Number of poles	1 pole	1	1
15	Control voltage	24 V _{DC}	A	
		32 V _{DC}		F
		36 V _{DC}	B	
		48 V _{DC}	C	
		72 V _{DC}	D	
		84 V _{DC}		H
		96 V _{DC}		4
	110 V _{DC}	E		
	(on demand, please contact Sécheron) 220 V _{DC}		-	
16	Auxiliary contacts BMS ⁽¹⁾	1 switch CO - silver type		A1
		2 switch CO - silver type		E1
		1 switch PF - silver type	A4	
		2 switch PF - silver type		E4
		1 switch PF - Gold type		C4
		2 switch PF - Gold type		H4
		(Alternative brand) 1 switch PF - silver type		A2
		(Alternative brand) 2 switch PF - silver type		E2
		(Alternative brand) 1 switch PF - Gold type		C2
		(Alternative brand) 2 switch PF - Gold type		H2
17	Application type	(Polarized Direct Current) DC	A	
		BMS36.01 only - (alternating current AC) ⁽²⁾		B
18	Low voltage interface	Standard	A	
		Cage clamp 10-pole connector		B
19	Arc chute type	Integrated	A	
		Removable		B

⁽¹⁾ Please refer to application schemes pages 3 and 4. ⁽²⁾ In development.



Sécheron SA
Rue du Pré-Bouvier 25
1242 Satigny - Geneva
CH-Switzerland

www.secheron.com
Tel: +41 22 739 41 11
Fax: +41 22 739 48 11
ess@secheron.com

Signature:

Name:

Place and date:

SA02052BEN_A00-09.24