

HIGH-SPEED CIRCUIT BREAKER PANELS

ESTRA-**MBS-SECUB**



ESTRA

DC SWITCHGEAR & DISTRIBUTION BOARD



With a leading expertise in DC traction power substations, Sécheron is your major partner for electrification of DC traction networks, covering all activities from network design, calculation, engineering, to the production of the DC systems.

ESTRA product category covers all key equipment applied in DC distribution, integrating DC high-speed circuit breakers, disconnect switches, load break switches, control & protection relays, measuring amplifiers, etc. We can offer tailor made solutions based on modular concepts and standard products. Our equipment is developed on world leading technology and proven worldwide design and acceptance. Our customers and partners benefit through this offer of all our system skills and experience.

GENERAL INFORMATION

DC traction networks require safe power distribution and reliable control systems.

The MBS breaker panel is based on Sécheron traction DC protection experience, and proven technology components are applied for all major functions in this cubicle.

The DC switchgear serves as the control and protection equipment for the DC power distribution.

With automatized production facilities for assembly, wiring and testing of MBS range of cubicles, Sécheron can ensure a constant and top level quality for these products.

/// Light rail applications

The MBS-SECUB cubicle is a compact DC switchgear solution designed for DC traction substations powering light transportation systems such as tramways, LRT, trolleybuses, monorails and LIM.

MBS-SECUB completes the range of Sécheron DC switchgear that covers heavy duty transportation systems.

MBS-SECUB is the improved evolution of the SECUB which has been widely installed in various networks for more than 10 years.

MAIN BENEFITS

- ✓ Strong, compact and durable cubicle
- ✓ Modular construction
- ✓ Limited maintenance with easy access to all parts
- ✓ Possibility to install cubicle directly against a wall
- ✓ Front access to all equipment
- ✓ Safe and reliable

MAIN CHARACTERISTICS

	Symbol	Unit	MBS-SECUB
Standard product range			
Rated service current	I_{Ne}	[A]	2500
Rated voltage	U_{Ne}	[V _{DC}]	900
Circuit breaker type	-	-	UR26
Power frequency withstand voltage - Active part to earth (50 Hz, 1 min) ⁽¹⁾	U_a	[kV]	5.5/9.2
Main busbar	I_e	[kA]	Up to 6
Busbar rating - Connection	-	[A]	2500
Rated short-circuit current - T_{Nc} 100 ms (900 V _{DC})	I_{Nss} / \hat{I}_{Nss}	[kA]	70/100
Protection degree	-	-	IP20 or IP42
Ambient temperature range	T	[°C]	-5 to +40
Width	-	[mm]	500
Depth	-	[mm]	1400
Height	-	[mm]	2400
Typical weight	-	[kg]	500

⁽¹⁾ Compliant with OV4 category.

For further characteristics, please refer to the datasheet of the individual circuit breaker type.

STANDARDS

Sécheron considers itself as the equipment supplier that invests the most in the types testing and certification of its products. MBS is fully type tested and compliant with the railway standards:

- **IEC 61992 (EN 50123)** | Railway applications – Fixed installations – DC switchgear
- **IEC 60980 (EN 60980)** | Recommended practices for seismic qualification of electrical equipment of the safety system for nuclear generating stations

Main features	Symbol	Unit	MBS-SECUB
Rated voltage	U_{Ne}	[V _{DC}]	900
Rated service current	I_{Ne}	[A]	2500
Rated making & breaking capacity	I_{Nss} / \hat{I}_{Nss}	[kA]	70/100
Rated track time constant	T_{Nc}	[ms]	100
Duty classes	-	-	f, e, d
Degree of protection	-	-	IP42

Internal Arc tests – According to EN 50123-6/A1:2015 standard

Main features	Symbol	Unit	MBS-SECUB
Rated voltage	U_{Ne}	[V _{DC}]	900
Rated insulation voltage	U_{Nm}	[V]	1800
Prospective current under arcing conditions	$I_{Narc} / \hat{I}_{Narc}$	[kA]	50/70
Permissible arc duration	-	[ms]	150
Degree of protection	-	-	IP42



DESCRIPTION

The DC breaker panel type MBS-SECUB is a modular concept cubicle which integrates different functions and equipment in three compartments:

- Rear high-voltage busbar compartment
- Protection and control system
- High-speed circuit breaker trolley

/// Rear high-voltage busbar compartment

The high-voltage compartment is at the rear of the cubicle. It contains the main busbar, cable connections, voltage and current measuring and, where applicable, disconnecter switches.

/// Control and protection system

The control and protection system is located at the front of the cubicle. This low-voltage compartment contains low-voltage components and ensures the protection through the SEPCOS control & protection relay.

/// High-speed circuit breaker trolley

The high-speed circuit breaker (Sécheron UR series) is mounted on a removable four-wheeled trolley which can be easily withdrawn from the cubicle. The trolley also contains the line test device equipment. The HSCB is connected to the auxiliary circuits thanks to an unpluggable multiple connector and the breaker is connected to the high-voltage busbars by power finger connectors. All trolleys are exchangeable by one of the same type and are easy to manoeuvre.

Active equipment is located on the trolley.

Trolley positions

The withdrawable high-speed circuit breaker trolley has four positions:

- Service position
- Test position
- Disconnected position
- Removed position

When the trolley is in service position, the front high-voltage door is locked and it is not possible to access the trolley. When high-voltage is applied to the breaker, it must be open before the trolley can be moved from service to test position.

The trolley is moved from one position to another either manually by an external handle or electrically via the SEPCOS touch screen display. In this way, user's security is ensured. Trolleys can be encoded to ensure that they cannot be exchanged for a trolley of another type.



MBS-SECUB feeder panel



MBS-SECUB feeder trolley

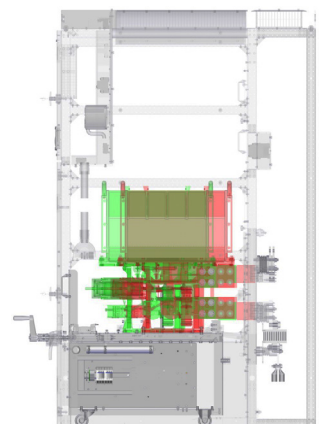

Service and test positions

APPLICATIONS

Line feeder

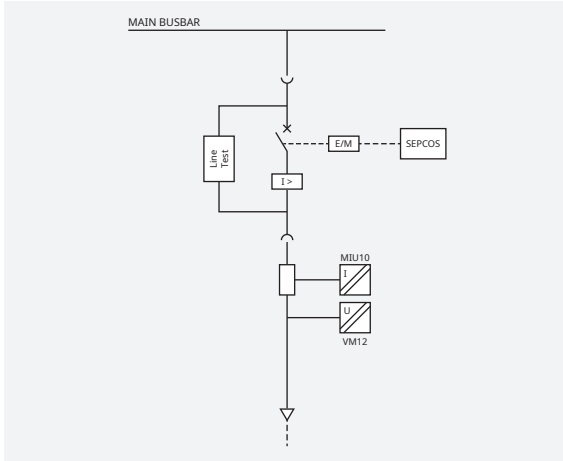

Line feeder with isolating switch

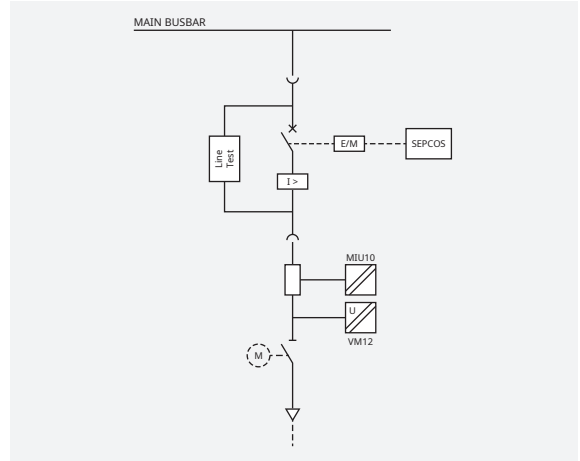

Line feeder with earthing switch

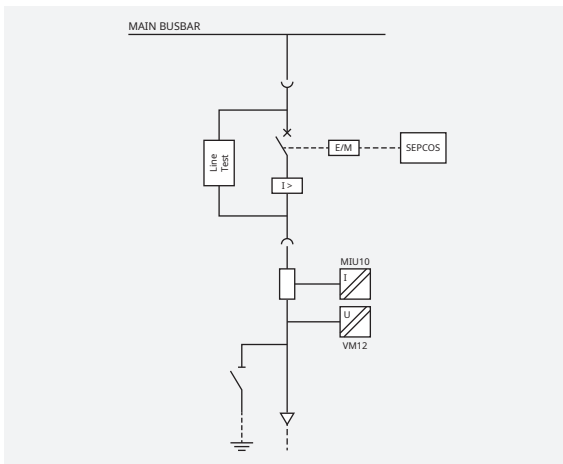

Rectifier breaker

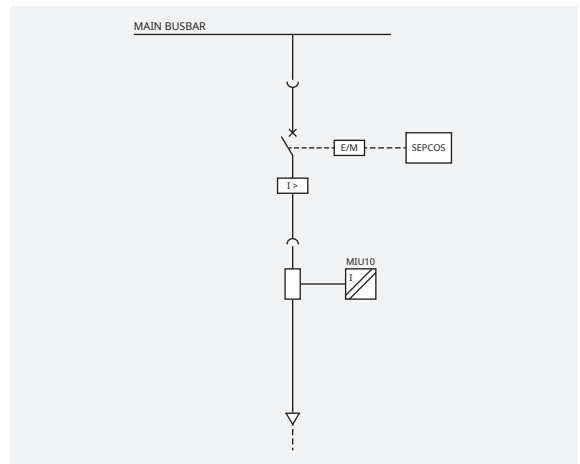

Line feeder with by-pass

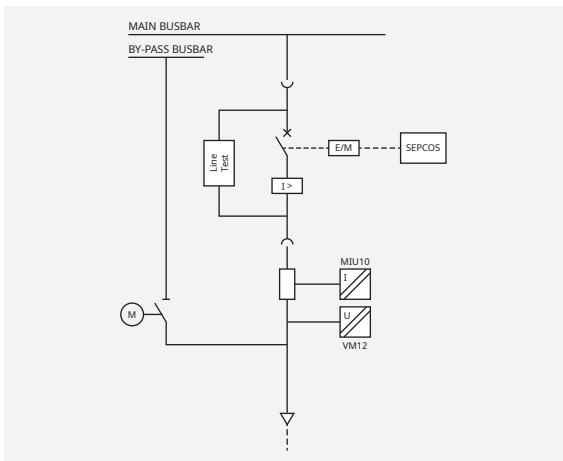

Line feeder with by-pass & isolating switch

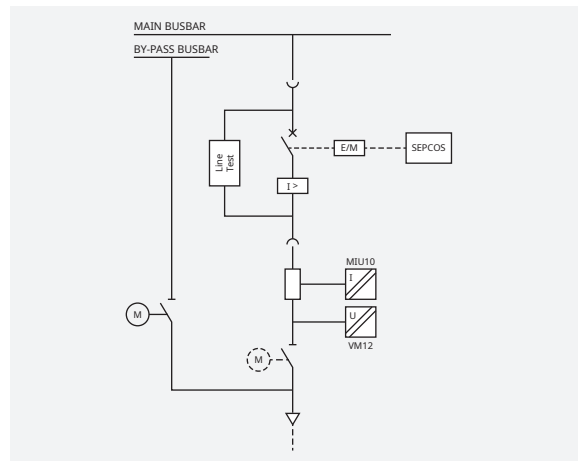

Installation of lightning arrester for outgoing feeder is available upon request. More available upon request.

MECHANICAL CHARACTERISTICS

COMPOSITION

Key components of the switchgear are designed and manufactured by Sécheron and are fully compatible.

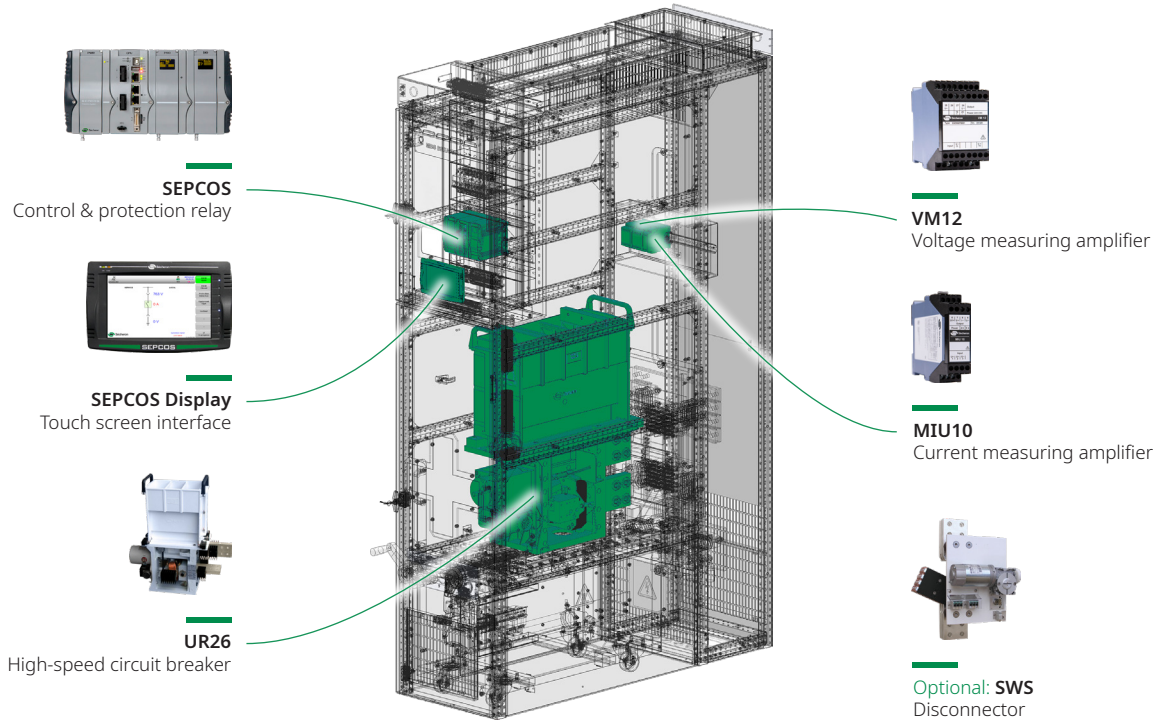

MAIN DIMENSIONS

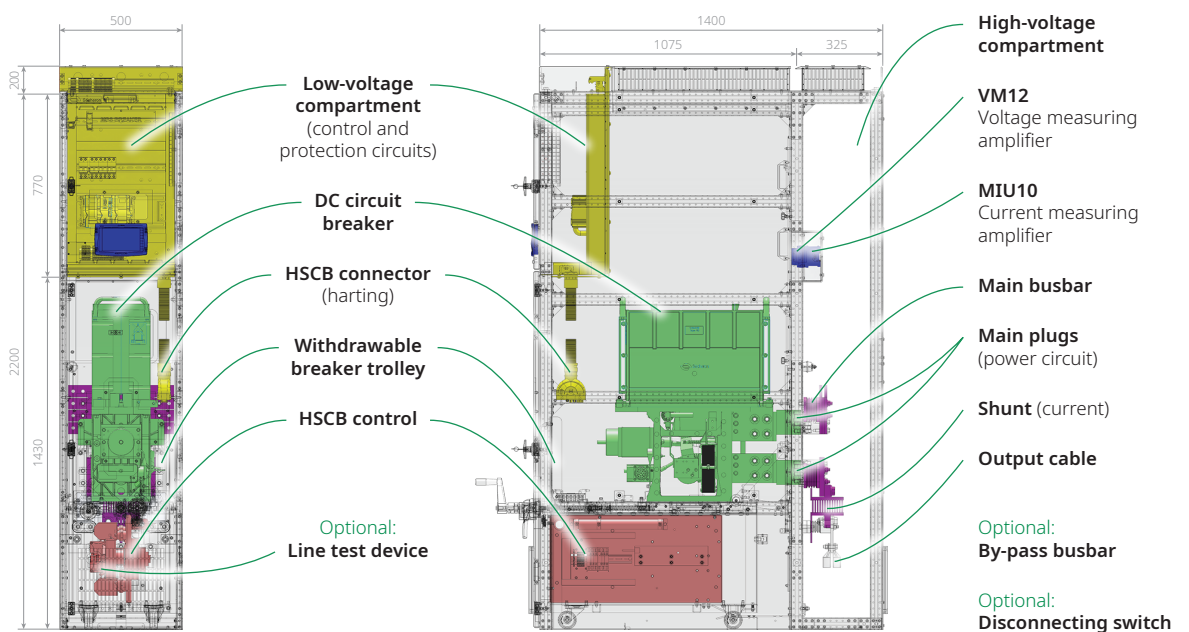

RELATED PRODUCTS

SEPCOS

CONTROL & PROTECTION RELAYS

SEPCOS is a control and protection unit that is applied to the outgoing feeder or the incoming HSCB cubicles in the DC traction substation.

Main features

- Modular PLC concept, PLC programming, IEC 61131 normalized programming
- Fully approved in railway substation environment IEC 60255-22
- High noise immunity thanks to sampling rate at 40 microseconds and 16 bits A-D converter

Protection functions

- All typical protection functions (e.g. DDL +/-, I_{max} +/-, etc.)

Control functions

- HSCB On/Off control with electric or magnetic holding
- Intertripping, automatic reclosing, anti-pumping, line test function
- External synchronization of the PLC, measurement supervisor control

Open to all customer networks and protocols

- TCP/IP: Modbus-TCP
- Specific TCP/IP based power distribution protocols: IEC 60870-5-104, IEC 61850, DNP 3.0
- Fieldbus: Modbus-RTU, Profibus-DP



Refer to **Brochure SEPCOS** · SG825866BEN

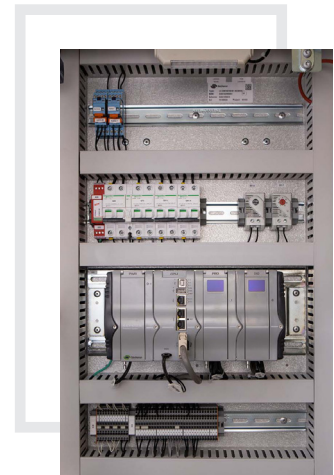

SEPCOS in a low-voltage compartment

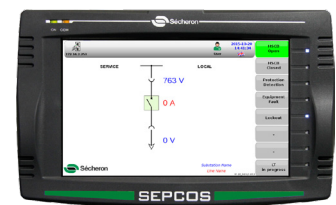

SEPCOS Display:

SEPCOS may be controlled and parametrized through a user-friendly 7" color touch screen display located on the front door of the cubicle.

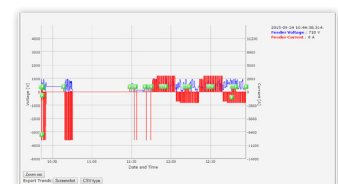

S-Web:

All functions are available through a web-server, including visualization trends.



SEPCOS-PRISM

CONTROL & PROTECTION RELAYS

- Compact product
- Door mounting
- Increase space in the low-voltage compartment



Refer to **Brochure SEPCOS-PRISM** · SG847023BEN



Sécheron SA

Rue du Pré-Bouvier 25
1242 Satigny - Geneva
CH-Switzerland

www.secheron.com

Tel: +41 22 739 41 11
Fax: +41 22 739 48 11
tps@secheron.com

Copyright © • 2024 • Sécheron SA

This document is not contractual and contains information corresponding to the level of technology at the date of printing. Sécheron reserves the right to modify and/or improve the product, whose characteristics are described in these documents, as required by new technology at any time. It is the purchaser's responsibility to inform himself, no matter what the circumstances, of the product's maintenance conditions and requirements. Sécheron reserves all rights, especially those arising from our "General Delivery Conditions".