

# REVERSIBLE CONTROLLED CONVERTERS

EFFICIENT-**REV**



# EFFICIENT

## POWER CONVERSION



Using experience accumulated over more than 50 years working in the field of traction power substations, Sécheron has designed the EFFICIENT product category from the ground up to cover all the customer needs for DC supplies.

All EFFICIENT products are built specifically to comply with the most stringent requirements of usability, maintainability and durability in traction power application environments, maximizing the return of investment for our customers. These reliable and field-proven building blocks are also the basis for custom applications upon specific requests.

# GENERAL INFORMATION

## APPLICATIONS

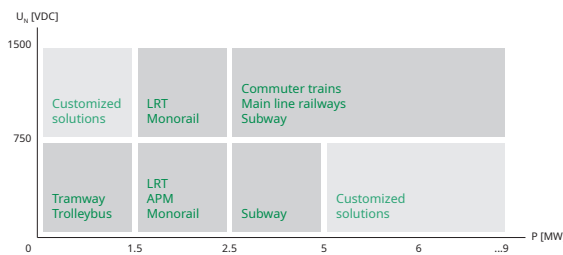

Combining our know-how in traction rectifiers with the latest energy recovery technologies, Sécheron is able to offer double converters for fully controlled reversible DC substations.

Using modular configurations, the REV reversible controlled converters can handle the asymmetrical power flow of traction acceleration and braking while maintaining constant DC voltage in narrow regulation range.

## MAIN BENEFITS

- ✓ Braking energy recovery
- ✓ Modular design for easy maintenance
- ✓ Multiple configurations available with different levels of redundancy
- ✓ Independence of rectifier and inverter functions for an increased availability
- ✓ Rectifier and inverter elements independently dimensioned according to project requirements
- ✓ System design and protection coordination with Sécheron switchgear to enhance reliability
- ✓ Robust thyristor rectifier design ensures reliable supply of the DC line
- ✓ Avoids voltage drops on the DC line in rectifier mode

# MAIN CHARACTERISTICS

Standard converter range	Unit	Values			
		750 V		1 500 V	
Mode		Rectifier	Inverter	Rectifier	Inverter
Rated DC voltage	[V]	750 - 1 000		1 500 - 1 950	
Rated power	[MW]	0.5 - 2	0.5 - 1.5	1 - 3	1 - 3
Maximum power	[MW]	9	4.5	9	9
AC frequency	[Hz]	50/60	50/60	50/60	50/60
Efficiency	[%]	> 98.5	> 97	> 98.5	> 97
Power factor	-	Up to 0.9 <sup>(1)</sup>	≈ 1	Up to 0.9 <sup>(1)</sup>	≈ 1
THDi	[%]	< 5 <sup>(1)</sup>	< 5 <sup>(1)</sup>	< 5 <sup>(1)</sup>	< 5 <sup>(1)</sup>
Control	-	Phase control	PWM	Phase control	PWM
Cooling	-	Natural air	Forced air	Natural air	Forced air
Temperature range (without derating)	[°C]	-5 / +40	-5 / +40	-5 / +40	-5 / +40
Protection degree	-	Up to IP32	Up to IP32	Up to IP32	Up to IP32
Noise level	[dB]	65	75	65	75
Power frequency withstand voltage	[kV]	4.6	4.6	6.9	6.9

<sup>(1)</sup>Note: In thyristor converters, the power factor and THDi are determined by the transformer's parameters.

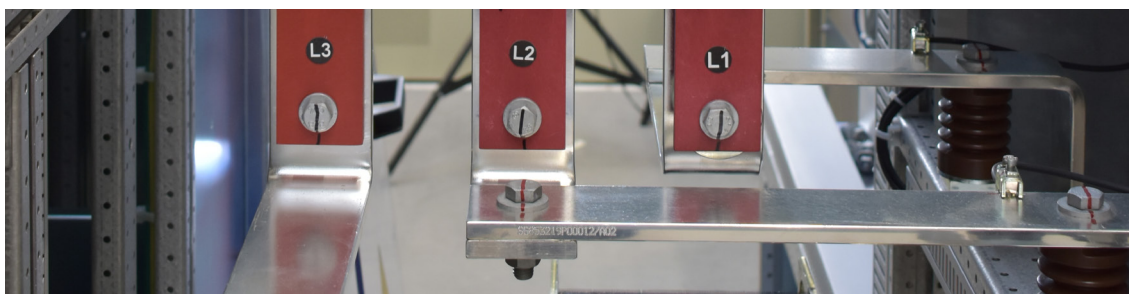

## STANDARDS

Our reversible controlled converters are compliant and type tested according to the following standards:

- **IEC 62497 (EN 50124)** | Railway applications – Insulation coordination
- **IEC 60146 (EN 60146)** | Semiconductor converters
- **IEC 62590 (EN 50328)** | Railway applications – Fixed installations – Electronic power converters for substations
- **IEC 60850 (EN 50163)** | Railway applications – Supply voltages of traction systems
- **IEC 62236 (EN 50121)** | Railway applications – Electromagnetic compatibility
- **IEC 60076 (EN 60076)** | Power transformers
- **IEEE 519** | Recommended Practices and Requirements for Harmonic Control in Electrical Power Systems
- **IEEE P1653.5** | Recommended Practice for Controlled Rectifiers for Traction Power Substation Applications

# CONNECTIONS

## Connections overview

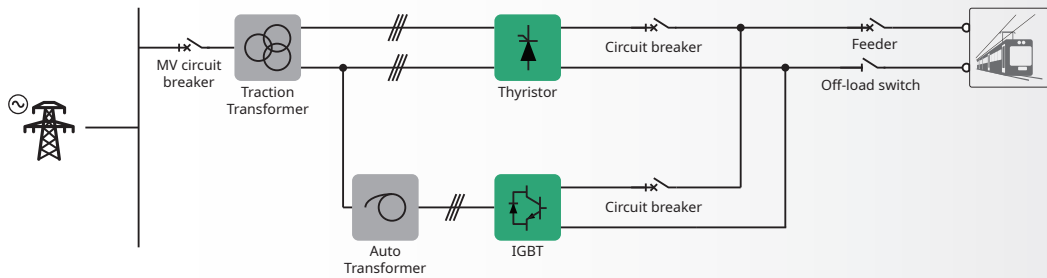

## Detailed connections schematic

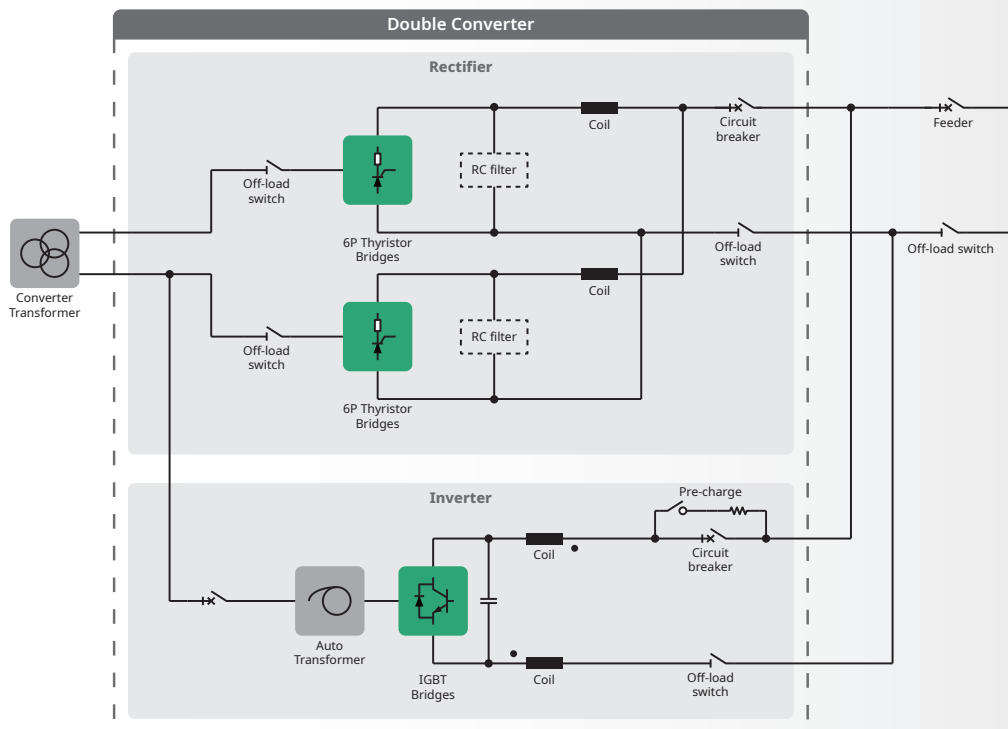

# CONTROL MODE

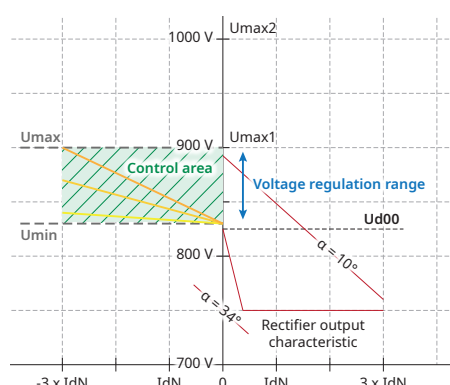

## Voltage control

In rectifier mode, the firing angle is regulated at any time to maintain the DC output voltage at a defined level. The voltage regulation compensates for the inductive and resistive voltage drops over the whole load range.

In inverter mode, the modulation width is regulated at any time to maintain the DC voltage at a defined level. The V/I characteristic is adapted depending on the rolling stock requirements.

# PROTECTIONS

## OVERVOLTAGE PROTECTION

### Internal overvoltage

During turn-off, the load current of the thyristor does not stop flowing immediately but continues briefly in reverse direction as reverse recovery current. This peak reverse recovery current causes a voltage peak which is eliminated by an individual snubber circuit mounted in parallel with each thyristor.

### External overvoltage

External overvoltages are essentially due to lightning strikes on the line and interrupted short-circuits. While RC filters are capable of absorbing a significant surge, snubbers share the voltage between thyristors and protect them individually.

## SHORT-CIRCUIT PROTECTION

INV-T inverters are designed to withstand internal and external short circuits without damaging the AC or the DC side thanks to circuit breakers.

## OTHER PROTECTIONS

### Over-temperature

Over-temperature detection devices are provided with the equipment to avoid failures due to an abnormal increase of temperature.

### Enclosure frame leakage (optional)

The inverter enclosure is isolated from the floor and connected to the station's ground via the frame leakage current sensor.

### Surge protection device (optional)

The inverter is optionally equipped with surge arresters.

### Auxiliary supply failure

The system monitors the health of the auxiliary control power source.

### Over-current

Inverter over-current causes tripping of the AC circuit breaker and of the inverter DC HSCB.

### Solenoid door interlocks (optional)

Solenoid door interlocks prevent the opening of enclosure doors if there is AC or DC voltage present on the system for safety.

# OPTIMIZED INVESTMENT

Sécheron provides engineering support to ensure an optimized investment in fixed installation assets based on customer specifications.

## /// Safety & reliability

Based on Sécheron's ample experience, the protective devices present in the inverter and the complete substation are carefully coordinated to ensure optimal protection. Breakers, brake choppers and other protective devices are configured to ensure safety and to preserve the acquired assets.



## /// Remote control monitoring & diagnostics

The inverter includes a SEPCOS system, allowing connection to all types of communication bus and protocols.

# LOAD CYCLES

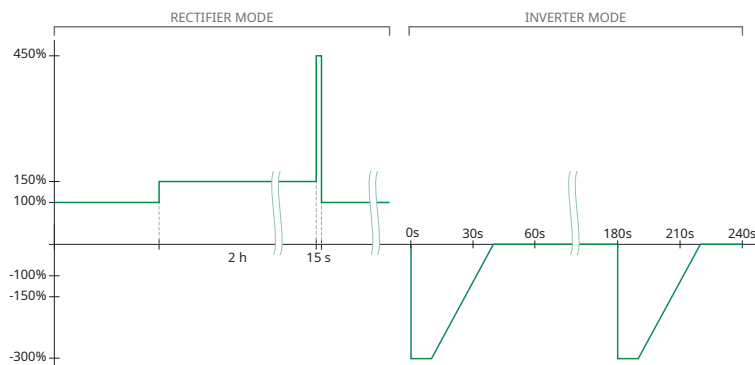

The power flow of a traction substation is several times more in rectification mode than in inversion mode. REV converters combine a rectifier and an inverter which are sized independently to fit the asymmetrical power profile.

While rectifiers mainly present load profiles requiring the supply of a 150% power for 2h, inverters usually only require a pulse load cycle. Indeed, losses help the train decelerate. Customer requirements are analysed to provide the optimal solution.

# TRANSFORMER-RECTIFIER GROUP

Based on strong experience, Sécheron provides engineering and consulting support services for transformers according to standards IEC 62695 (EN 50329) and IEEE 1653.1:

- Technical specification
- Monitoring during manufacturing process with the supplier
- Assistance during factory acceptance tests
- Assistance during combined tests of the complete transformer-rectifier group

The inverter is connected to the rectifier transformer with an autotransformer. Autotransformers present the advantage of saving about 70% of copper compared with a transformer, saving material resources and lowering the inverter cost. The withdrawable LV AC-circuit breaker that replaces MV-switchgear also acts as a disconnecter.



To ensure the compatibility of rectifier and transformer, Sécheron is able to provide the complete transformer-rectifier group.

## RELATED PRODUCTS

### REC-D & REC-T

#### DIODE & THYRISTOR RECTIFIERS

Sécheron's REV is designed for optimal coordination with REC-D and REC-T, ensuring compatibility for protection and operation.



Refer to **Brochure REC-D** • SG825863BEN  
Refer to **Brochure REC-T** • SG841750BEN



### INV-I & INV-T

#### IGBT & THYRISTOR INVERTERS

INV-I and INV-T can be provided with newly installed or already existing diode or thyristor rectifiers, using their dedicated MV-transformer.



Refer to **Brochure INV-I** • SG839109BEN  
Refer to **Brochure INV-T** • SG839110BEN



**Sécheron SA**

Rue du Pré-Bouvier 25  
1242 Satigny - Geneva  
CH-Switzerland

**[www.secheron.com](http://www.secheron.com)**

Tel: +41 22 739 41 11  
Fax: +41 22 739 48 11  
[tps@secheron.com](mailto:tps@secheron.com)

**Copyright © • 2024 • Sécheron SA**

This document is not contractual and contains information corresponding to the level of technology at the date of printing. Sécheron reserves the right to modify and/or improve the product, whose characteristics are described in these documents, as required by new technology at any time. It is the purchaser's responsibility to inform himself, no matter what the circumstances, of the product's maintenance conditions and requirements. Sécheron reserves all rights, especially those arising from our "General Delivery Conditions".