

DISCONNECTOR

Type **SW**

FIXED INSTALLATION

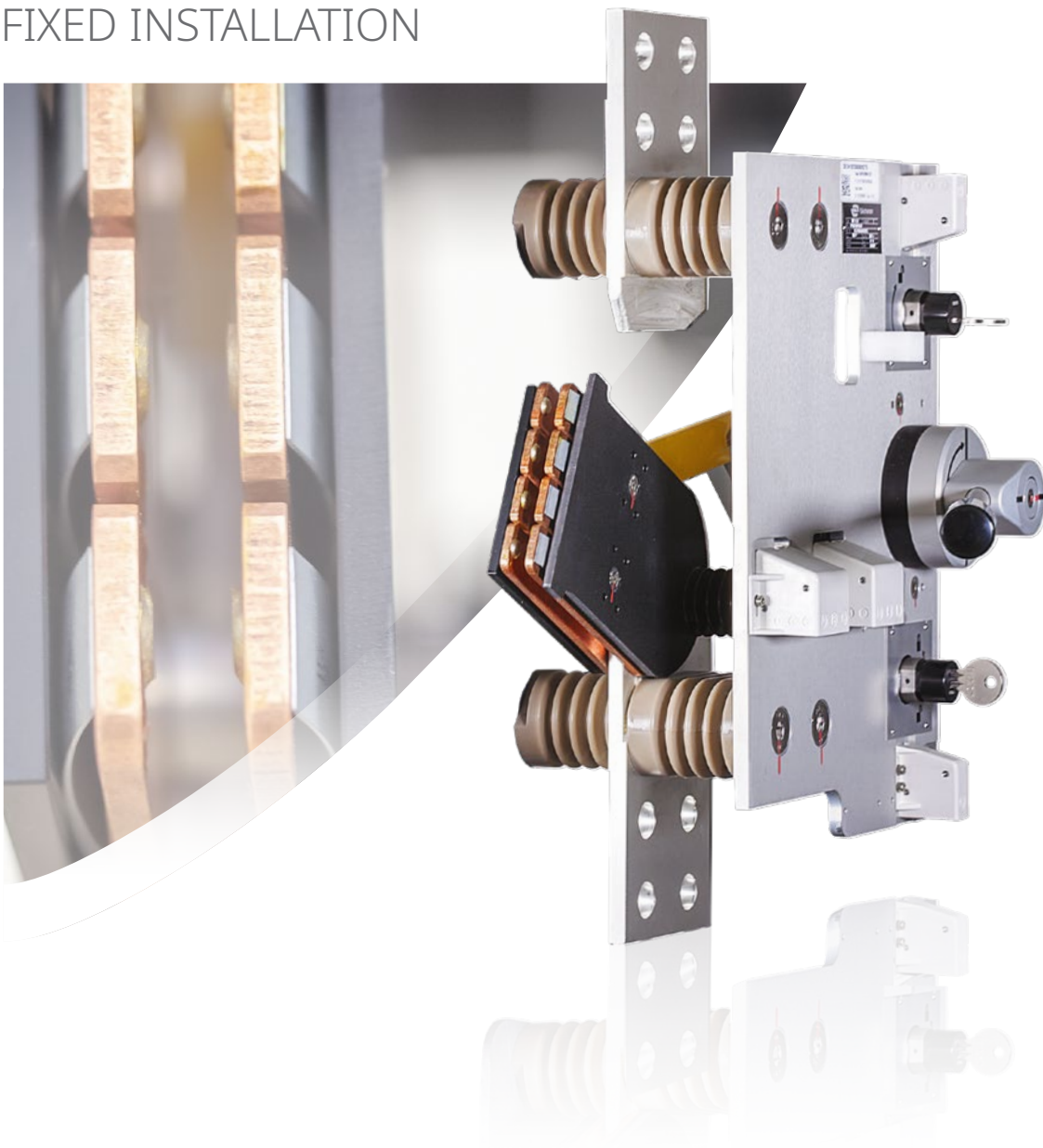

GENERAL INFORMATION

The **SW** off-load disconnector is a complete range designed to cover all the applications to be met in DC traction power substations and other industrial applications. Its modular concept enables to build single pole or double pole **SWS** disconnectors, **SWI** selectors or **SWG** disconnectors with earthing, for insulation voltages 3,000 V_{DC/AC} or 4,800 V_{DC/AC} and rated insulation voltage from 2,000 to 8,000 A.

Installed inside cubicles, the **SW** disconnector can be operated either manually or electrically, and the customer can select among standard options safety interlockings made via key locks and/or electromagnets. The severe testing procedures applied for the type testing as well as for the serial testing make the **SW** disconnector a safe component with a unique design and a high level of reliability.

APPLICATIONS, TYPICAL EXAMPLES

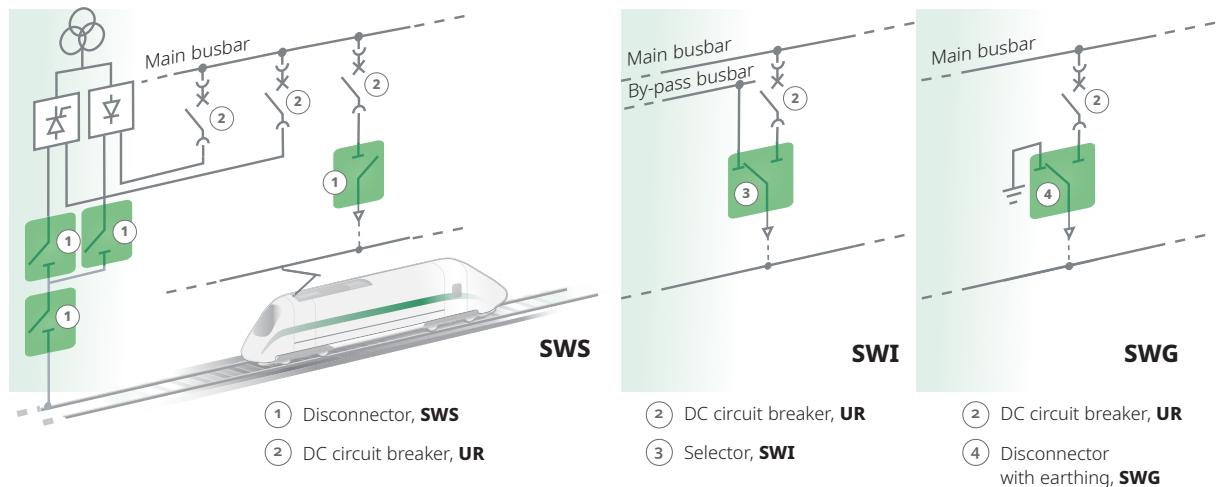

PRODUCT RANGE

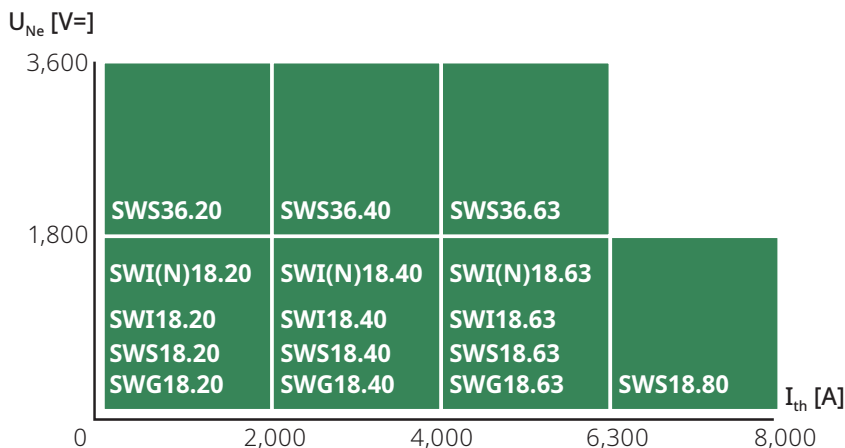
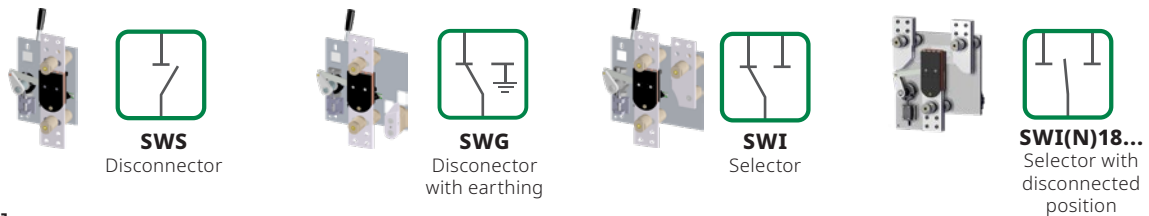

The selection of the appropriate current rating is function of the load cycle. Please refer to Overload capacity table page 5.

* SWI(N)18.63 (not available yet)
For any need, please contact Sécheron.

All products are available in 1 pole or 2 poles, except the following one which are only available in one pole: **SWS18.80, SWI(N)**.

MAIN FEATURES

- Rated operational voltage 1,800 V_{DC} and 3,600 V_{DC}
- Conventional free-air thermal current from 2,000 A to 8,000 A
- Safe with a high rated insulation voltage 3,000 V_{DC} and 4,800 V_{DC}
- 1 or 2 pole versions
- Specific version with 3 positions, SWI(N)18...
- Reference standards: EN 50123-1/-3

MAIN BENEFITS

- ✓ Compact size.
- ✓ High rated short-time withstand current value.
- ✓ Safe with the high voltage circuit separated from the low voltage circuit.
- ✓ Silver-plated high voltage connections.
- ✓ Optional locking of the main contacts available with either key and/or electromagnet.
- ✓ High mechanical durability: 20,000 cycles minimum.
- ✓ Self cleaning contacts.
- ✓ High modularity to cover all necessary variants and options.
- ✓ Simple design with reduced number of parts.

HIGH MODULARITY

The below figures show the basic configuration of each SWS, SWI and SWG device (for a current of 2,000 A and a voltage of 1,800 V_{DC}).

All these devices are also delivered in other configurations of current, voltage, operation and number of pole, thanks to a high industrialized modularity as shown below.

SELECTION OF OPERATION

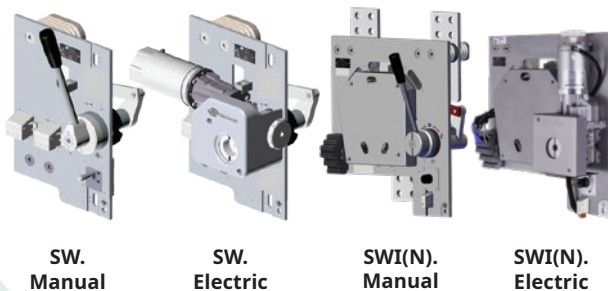

SELECTION OF RATED VOLTAGE

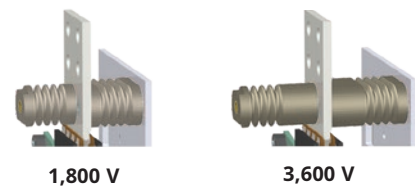

SELECTION OF POLE NUMBER

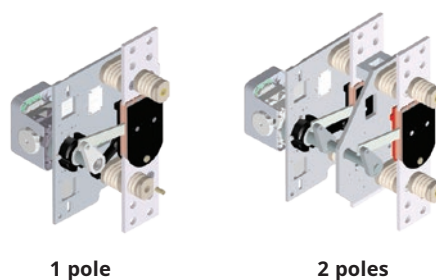

SELECTION OF RATED THERMAL CURRENT

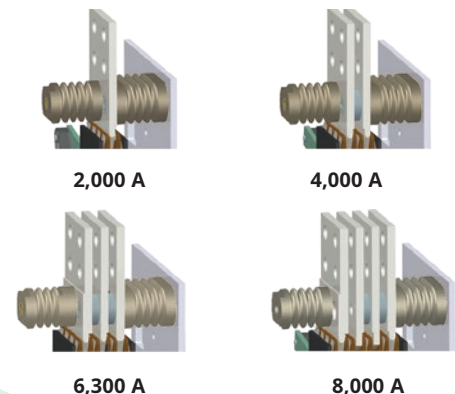

DATA FOR PRODUCT SELECTION

	Symbol	Unit	SW...20	SW...40	SW...63	SW...80
MAIN HIGH VOLTAGE CIRCUIT						
Rated operational voltage - SWS - SWI and SWG	U_{Ne}	[V _{DC}]	1,800 or 3,600 1,800		1,800 or 3,600 1,800	1,800 -
Rated insulation voltage - SWS - SWI and SWG	U_{Nm}	[V]	3,000 or 4,800 3,000		3,000 3,000	3,000 -
Rated service current	I_{Ne}	[A]	2,000	4,000	6,300	8,000
Conventional free air thermal current ⁽¹⁾	I_{th}	[A]	2,000	4,000	6,300	8,000
Peak and rated short-time withstand current ⁽²⁾ - for U_{Ne} 1,800 V (excepted for SWI(N) 18...) - for U_{Ne} 3,600 V	$\hat{I}_{Ncw}/I_{Ncw}/t$ [kA]/[kA]/[s]		178/125/0.25 142/100/0.25		178/125/0.25 142/100/0.25	-
Overvoltage category			OV4		OV4	
Rated power-frequency withstand voltage ⁽³⁾ - Pole - Pole - Pole - Earth	U_a	[kV]	11.0 ⁽⁴⁾ / 22.2 ⁽⁵⁾ 9.2 ⁽⁴⁾ / 18.5 ⁽⁵⁾		11.0 ⁽⁴⁾ / 22.2 ⁽⁵⁾ 9.2 ⁽⁴⁾ / 18.5 ⁽⁵⁾	11.0 ⁽⁴⁾ 9.2 ⁽⁴⁾
Rated impulse withstand voltage (1.2/50 μ s) - Pole - Pole - Pole - Earth	U_{Ni}	[kV]	24.0 ⁽⁴⁾ / 48.0 ⁽⁵⁾ 20.0 ⁽⁴⁾ / 40.0 ⁽⁵⁾		24.0 ⁽⁴⁾ / 48.0 ⁽⁵⁾ 20.0 ⁽⁴⁾ / 40.0 ⁽⁵⁾	24.0 ⁽⁴⁾ 20.0 ⁽⁵⁾

⁽¹⁾ At $T_{amb} = +40^\circ\text{C}$ and tested with high voltage connections according to standard IEC/EN 60943. • ⁽²⁾ For specific values of the SWG earthing pole, refer to the figure and table of the page 5 • ⁽³⁾ At 50 Hz and during 1 minute • ⁽⁴⁾ For $U_{Ne} = 1,800$ Vdc • ⁽⁵⁾ For $U_{Ne} = 3,600$ Vdc •

LOW VOLTAGE AUXILIARY CIRCUIT

Control circuit (motor and optional electromagnet lock)

Nominal voltage	U_n	[V _{DC}] [V _{AC}]	24, 48, 60, 110, 125, 220 127 (50/60 Hz), 230 (50/60 Hz) (for all SW...except SWI(N))			
Range of voltage			[0.8-1.1] U_n			
Motor nominal closing/opening power: - DC only - AC only		[W]	125 90 (for all SW...except SWI(N))			
Mechanical switching time ⁽⁶⁾	t_c	[S]	< 3 (SW... with DC motor) < 5 (SW... with AC motor)			
Electromagnet nominal power (DC and AC)		[W]	~14			

⁽⁶⁾ For motorized version, at nominal control voltage = U_n and $T_{amb} = +20^\circ\text{C}$. For SWI(N), switching time from left or right position to intermediate one and vice and versa.

Auxiliary contacts for main circuit and optional locks

Type of contacts (refer to definition page 10)			Changeover (CO)			
Rated voltage		[V _{DC}] [V _{AC}]	24 to 220 230			
Conventional thermal current	I_{th}	[A]	10			
Maximum breaking capacity at 110 V _{DC} and $t=5$ ms		[A]	0.75			
Minimum let-through current at 24 V _{DC} ⁽⁷⁾		[mA]	10 (silver contacts)			

⁽⁷⁾ For a dry and clean environment.

Low voltage interface

Type of connection			Direct for auxiliary contact Terminal block for motor			
--------------------	--	--	--	--	--	--

Insulation

Rated power-frequency withstand voltage ⁽⁸⁾	U_a	[kV _{rms}]	2			
--	-------	----------------------	---	--	--	--

⁽⁸⁾ At 50 Hz and during 1 minute.

OPERATING CONDITIONS

Installation			Indoors			
Altitude		[m]	$\leq 2,000$			
Working ambient temperature	T_{amb}	[°C]	- 25 to +40			
Humidity			Class 5k2			
Pollution degree			PD4			
Minimum mechanical durability	N	Cycles	20,000			

OVERLOAD CAPACITY

		SWG...20	SWG...40	SWG...63	SWG...80
Application Duty Class - I_{Bd} [A] EN 50328 / IEC 62590	Class I	2,000	4,000	6,300	8,000
	Class V, VI, VII	2,000	3,000	4,200	—
	Class VIII	1,600	3,000	4,200	—

I_{Bd} : basic direct current

Class I	$1 \times I_{Bd}$	continuously
Class V	a) $1 \times I_{Bd}$	continuously
	b) $1.5 \times I_{Bd}$	2 hours - after a)
	c) $2.0 \times I_{Bd}$	1 min - after a)
Class VI	a) $1 \times I_{Bd}$	continuously
	b) $1.5 \times I_{Bd}$	2 hours - after a)
	c) $3.0 \times I_{Bd}$	1 min - after a)
Class VII	a) $1 \times I_{Bd}$	continuously
	b) $1.5 \times I_{Bd}$	2 hours - after a)
	c) $4.5 \times I_{Bd}$	15 s - after a)
Class VIII	a) $1 \times I_{Bd}$	continuously
	b) $1.5 \times I_{Bd}$	2 hours - after a)
	c) $2.0 \times I_{Bd}$	1 min - after b)

PEAK AND RATED SHORT-TIME WITHSTAND CURRENTS OF THE SWG EARTHING POLE

The earth connection can be a cable or a flexible braid according to the current value.

The values of the peak and rated short-time withstand currents are depending on the position/orientation of the earth connection.

CONNECTION OF EARTH CABLE (UPWARDS)

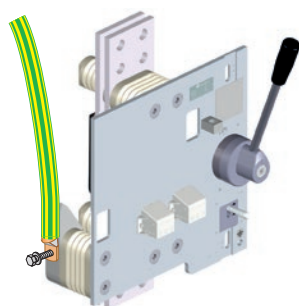

CONNECTION OF EARTH CABLE (DOWNWARDS)

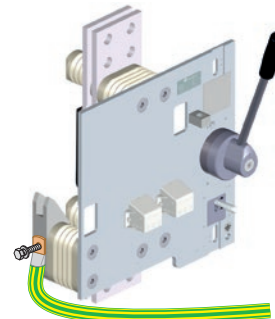

VALUES OF THE PEAK AND RATED SHORT-TIME WITHSTAND CURRENTS

	Symbol	Unit	SWG..20	SWG..40	SWG..63
Earth connection (Upwards)	I_{Ncwe}	[kA]	14	28	28
	\hat{I}_{Ncwe}	[kA]	20	40	40
	t	[s]	0.25	0.25	0.25
Earth connection (Downwards)	I_{Ncwe}	[kA]	14	14	28
	\hat{I}_{Ncwe}	[kA]	20	20	40
	t	[s]	0.25	0.25	0.25

I_{Ncwe} : rated short-time withstand current
 \hat{I}_{Ncwe} : peak short-time withstand current
 t: short-time current duration

INFORMATION FOR PRODUCT INTEGRATION

MAIN DIMENSION

The DIN-ISO 2768-1 coarse tolerances are applied to these dimensions. All dimensions are in mm.

Note: Each SW can be equipped with manual or motorized (DC or AC) operation.

SW.18...

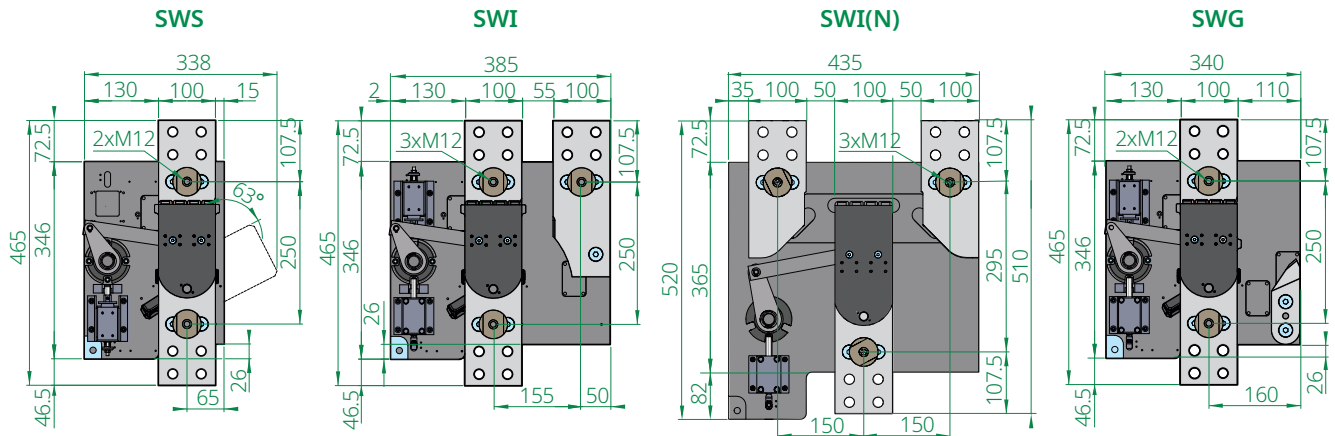

SW.18.20

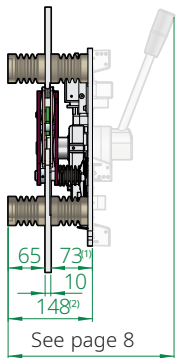

SW.18.40

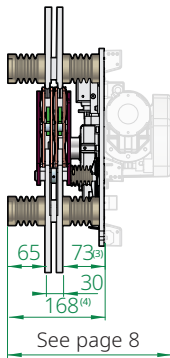

SW.18.63

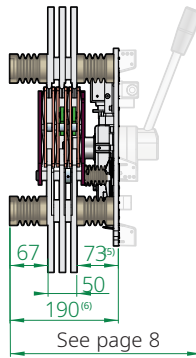

SW.18.80

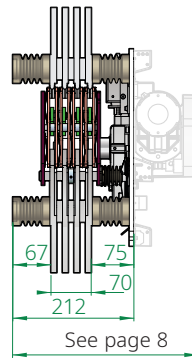

SW.18... 1-POLE configurations

- (1) 75 for SWI(N)18.20.
- (2) 150 for SWI(N)18.20.
- (3) 75 for SWI(N)18.40.
- (4) 170 for SWI(N)18.40.
- (5) 75 for SWI(N)18.63*.
- (6) 193 for SWI(N)18.63*.

* SWI(N)18.63 (not available yet)
For any need, please contact Sécheron.

SW.18.20

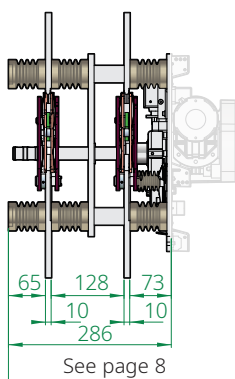

SW.18.40

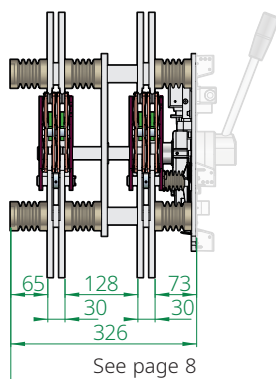

SW.18.63

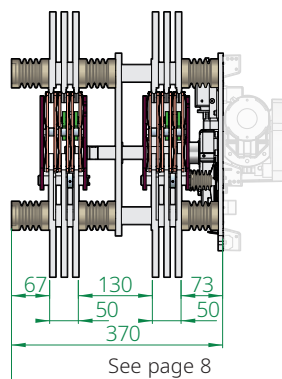

SW.18... 2-POLE configurations

SWS36...

SWS

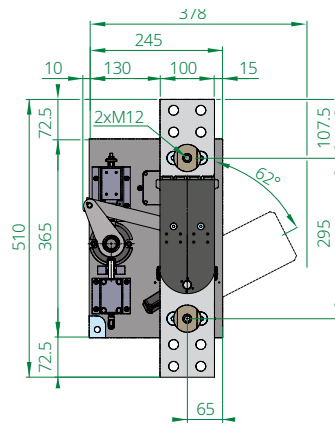

SWS36...
1-POLE
configurations

SWS36.20

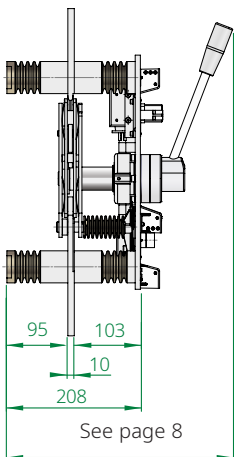

See page 8

SWS36.40

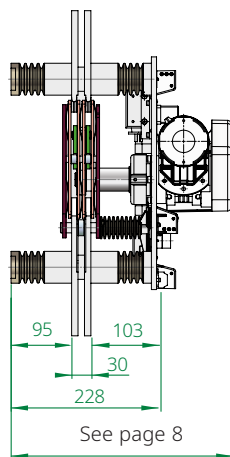

See page 8

SWS36.63

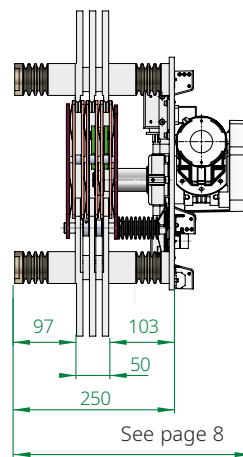

See page 8

SWS36...
2-POLE
configurations

SW.36.20

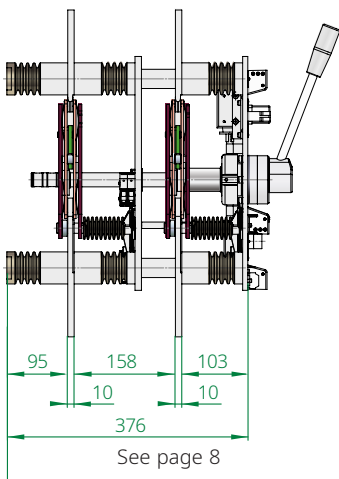

See page 8

SW.36.40

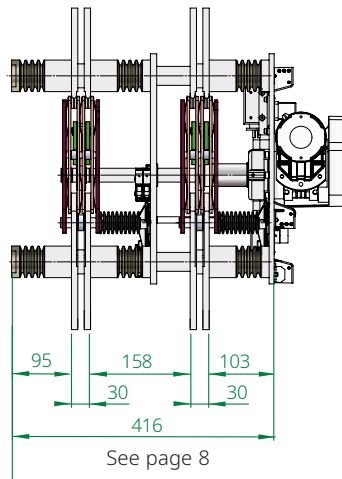

See page 8

SW.36.63

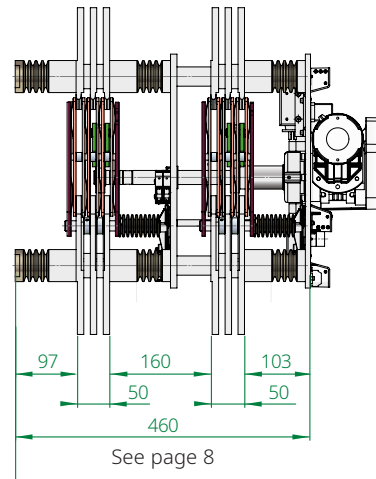

See page 8

OPERATION

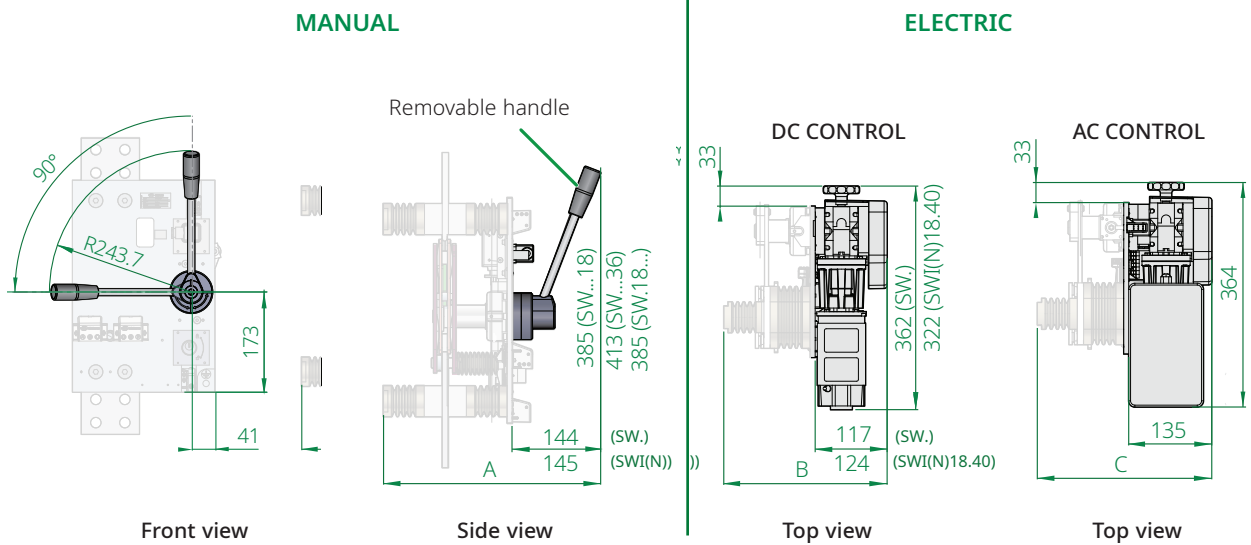

DIMENSIONS		A	B	C
SW.18.20	- 1 pole/2 pole	292/430	265/403	283/421
SWI(N)18.20	- 1 pole/2 pole	295/433	273/411	Not applicable
SW.18.40	- 1 pole/2 pole	312/470	285/443	303/461
SWI(N)18.40	- 1 pole/2 pole	315/473	293/451	Not applicable
SW.18.63	- 1 pole/2 pole	334/515	307/488	325/506
SW.18.80	- 1 pole	357	330	348
SWI(N)18.63*	- 1 pole/2 pole	337/517	313/495	Not applicable
SWS36.20	- 1 pole/2 pole	352/520	325/493	343/511
SWS36.40	- 1 pole/2 pole	372/560	345/533	363/551
SWS36.63	- 1 pole/2 pole	394/605	367/578	385/596

All dimensions are in mm

* SWI(N)18.63 (not available yet)
For any need, please contact Sécheron.

DETAILS OF THE HIGH VOLTAGE CONNECTIONS

The busbars or cables must be mechanically fixed outside the SW disconnector, and their contact surface must be parallel to the HV connections:

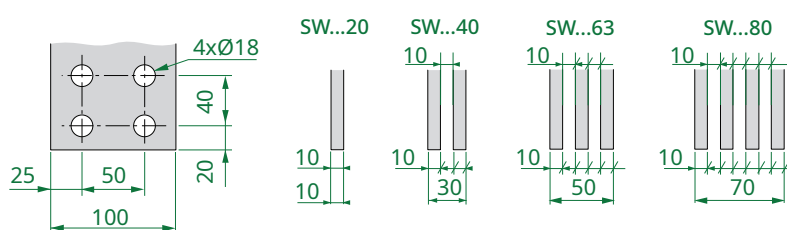

FOR ALL DEVICES

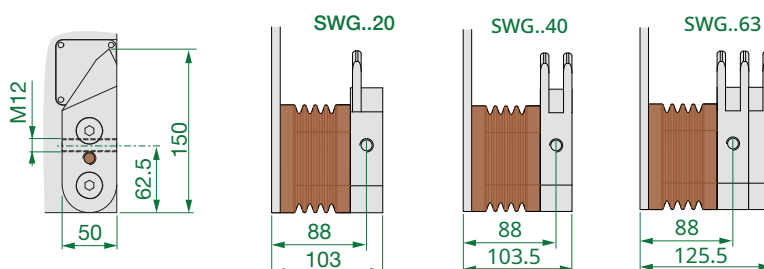

SWG EARTHING POLE

DETAILS OF THE EARTH CONNECTION ON THE BASE PLATE

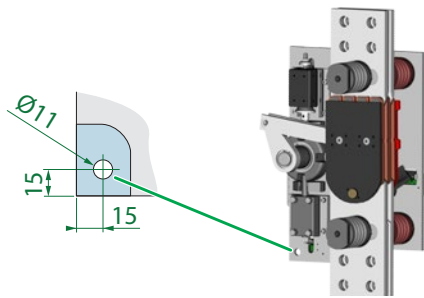

WEIGHTS

SWS	1 pole						2 poles							
	18.20	18.40	18.63	18.80		36.20	36.40	36.63	18.20	18.40	18.63	36.20	36.40	36.63
MA [kg]: ± 1 kg	10	14	18	22		12	16	20	18	26	34	22	30	*
MO [kg]: ± 1 kg	16	20	24	28		18	22	26	24	32	40	28	36	*

SWI	1 pole			2 poles		
	18.20	18.40	18.63	18.20	18.40	18.63
MA [kg]: ± 1 kg	15	21	27	25	37	49
MO [kg]: ± 1 kg	21	27	33	31	43	55

SWI(N)	1 pole		
	18.20	18.40	18.63 ⁽¹⁾
	-	-	-
	22	28	34

* On request
⁽¹⁾ SWI(N)18.63 (not available yet)
 For any need, please contact Sécheron.

SWG	1 pole			2 poles		
	18.20	18.40	18.63	18.20	18.40	18.63
MA [kg]: ± 1 kg	12	18	24	23	35	47
MO [kg]: ± 1 kg	18	24	30	29	41	53

Additional info.

MA: manual operation
 MO: electric operation

The given weight corresponds to the heaviest AC motor configuration.

For DC motor, weights are slightly lower.

Weight may be different depending on product configuration with options.

SW FIXATION

EXAMPLE OF EXECUTIONS

SWI

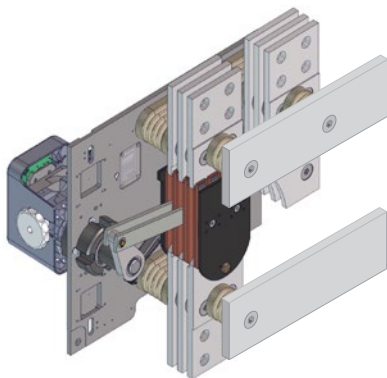

SWS-SWG

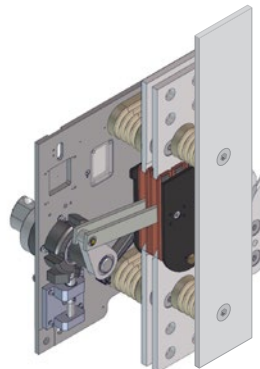

The SW series switches are fixed vertically as shown here by means of M12 screws.

LOW VOLTAGE CONTROL AND INTERFACES

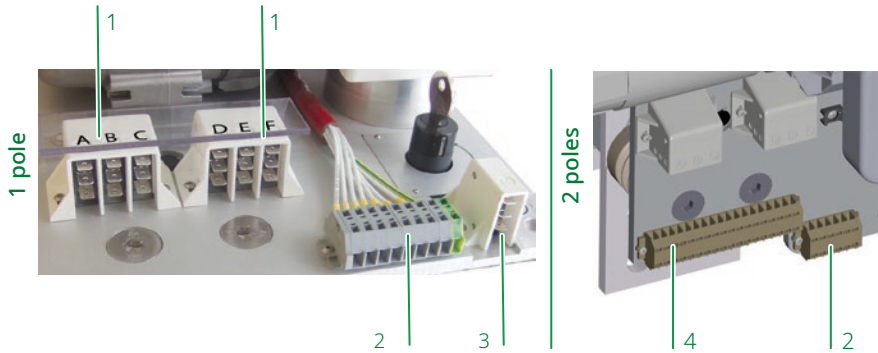

Legend of the schemes:

1. Direct connection (faston) on auxiliary switches for SW open/close status (one pole version).
2. Terminal block for motor control only.
3. Direct connection (faston) on auxiliary switches for optional locks.
4. Terminal block to connect the auxiliary switches of each pole for SW open/close status (two poles version).

CONTROL DIAGRAM FOR DC VOLTAGE MOTOR

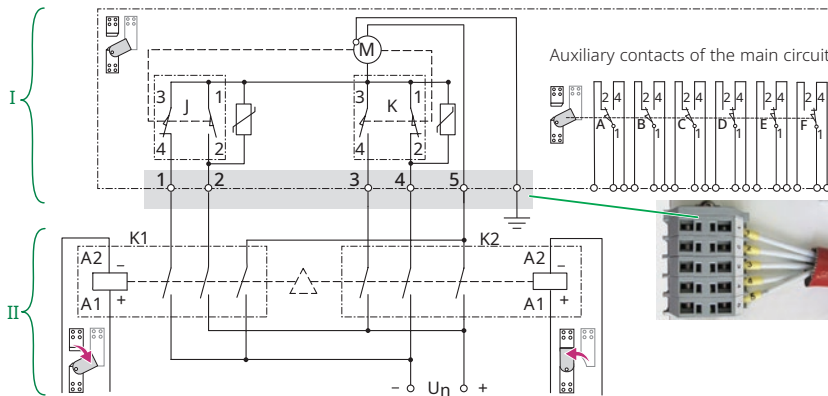

Control scheme valid for all SW... except SWI(N)18.40 which scheme is available on request.

As the motor needs to be dynamically braked, make the external circuit (II) as shown on this diagram:

Legend of the schemes:

- I. SW scope.
SW scope.
- II. Customer scope.
Both contactors K1 and K2 must be mechanically interlocked to avoid them to be triggered at the same time; and each of them must have three NO contacts.

CONTROL DIAGRAM FOR AC VOLTAGE MOTOR

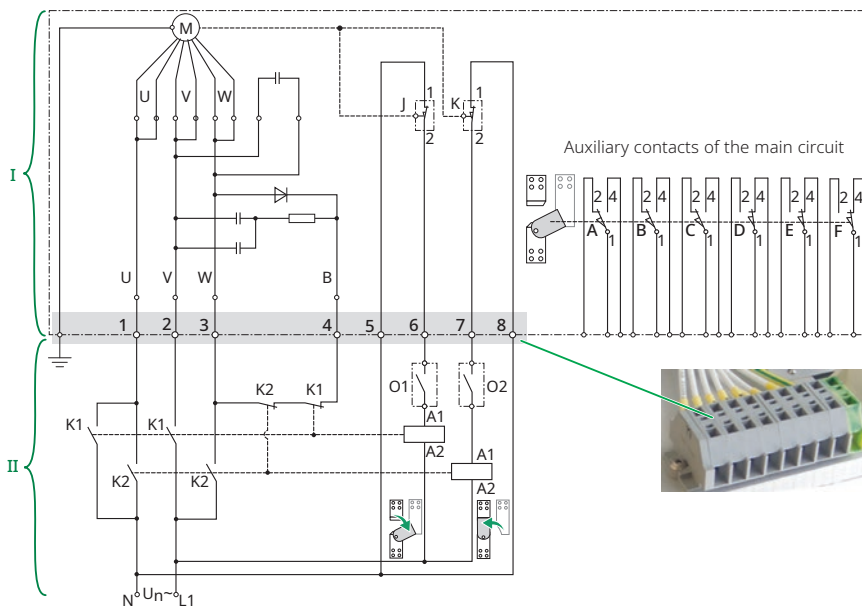

As the motor needs to be dynamically braked, make the external circuit (II) as shown on this diagram:

Legend of the schemes:

- I. SW scope.
SW scope.
- II. Customer scope.
Each of the K1 and K2 contactors must have two NO and one NC contacts.

This interface is for SWX only - it is a typical example. For other configuration please contact Sécheron.

LOCKING SYSTEMS

STANDARD

Manually operated units having no lock (key or electromagnet) to lock **SW** in close position are equipped with manual locking lever. A change-over auxiliary switch indicates the locking status of the lock system.

OPTIONAL (SUBJECT OF ADDITIONAL COSTS)

- ✓ Key lock system
- ✓ Keys can only be removed in locked positions. Key lock the moving contact in a defined position (open and/or closed).
- ✓ Key lock system is of Ronis type. For other type, please contact Sécheron.
- ✓ The electromagnet locks the moving contact in a defined position (open and/or closed).
- ✓ When the electromagnet is energized, the main contact is unlocked and can then be operated.
- ✓ A change-over auxiliary switch indicates the locking status of the lock system.
- ✓ SW with manual operation, except **SWI(N)**, can also be delivered with a simple padlock system enabling to lock the **SW** in OPEN position with up to 6 padlocks.
- ✓ A change-over auxiliary switch must be implemented in a control circuit for motor SW.

LOCKED POSITION OF MOVING CONTACT

Closed position

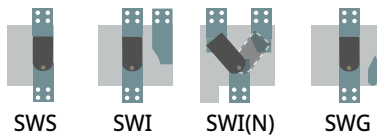

Open position

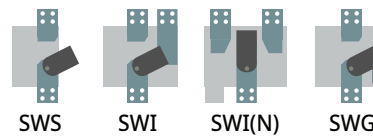

CONFIGURATION TABLE TO SELECT AND CODE THE LOCKING SYSTEM

As a complement to the below table, please note the following rules for your appropriate selection of lock configurations:

- **SW** with manual operation **MUST** be locked in both OPEN and CLOSED positions
- **SW** with electric operation cannot have key in upper position.
- **SWI(N)** is locked in the three positions of the moving contacts. Key lock system is placed in lower position only.

Key lock system		Electromagnet lock system		Designation code	
in Lower position	in Upper position	in Lower position	in Upper position	standard	option
-	-	-	-	0 ⁽¹⁾	-
	-	-	-	-	A ⁽²⁾
	-	-	-	-	B ⁽³⁾
	-	-	-	-	C
		-	-	-	D
	-	-		-	E
	-	-		-	F
	-	-		-	G
	-	-		-	H
-	-		-	-	I
	-	-		-	J
-	-		-	-	M
-	-		-	-	N
	-	-		-	P
Manually operated SWI(N)					
	-	-	-	-	K ⁽⁴⁾
-	-		-	-	L ⁽⁴⁾



MANUAL LOCKING LEVER (FOR MANUAL OPERATED DEVICE)



KEY LOCK SYSTEM



ELECTROMAGNET LOCK SYSTEM

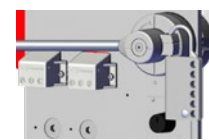

PADLOCK SYSTEM

Positions of the key lock systems

The key and electromagnet locks systems are located in upper position or lower position on the main plate.

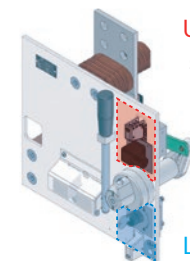

Upper position
second key location

Lower position
If only one key selected.

These symbols show in which position the moving contact is locked:



in open position



in closed position



in closed and open positions

(1) (2) (3) For these configurations combined with a manual operation of the SW, the device will be automatically delivered with a manual locking lever as per the following rules:

- (1) in the lower position, locking the main contacts in both open and closed positions.
- (2) in the upper position, locking the main contacts in open position.
- (3) in lower position, locking the main contacts in closed position.



meaning also in the intermediate position for **SWI(N)w**

- (4) Applicable to **SWI(N)** with manual operation only. Locking of the moving contacts in the three positions.

DESIGNATION CODE FOR ORDERING

- Be sure to establish the designation code from the latest version of our brochure by downloading it from the website: www.secheron.com
- Be careful to write down the complete alphanumerical designation code with 13 characters when placing your order.
- For technical reasons some variants and options indicated in the designation code might not be combined.
- For other configurations not described in the brochure, please contact Secheron.
- The bold characters of the designation code define the device type.

Example of customer's choice:	SW	I	18	40	MO	1	J	B	1
Line:	10	11	12	13	14	15	16	17	18

DESIGNATION CODE*

^(*)Options are subject to additional costs

Line	Description	Designation	standard	Options	Customer's choice
10	Product type	SW	SW		SW
11	Application	Disconnector Selector Selector with neutral position ⁽¹⁾ Disconnector with earthing	S I I(N) G		
12	Rated operational voltage	1,800 V 3,600 V	18 36		
13	Conventional free-air thermal current ⁽²⁾	2,000 A 4,000 A 6,300 A (For 1,800 V only) 8,000 A	20 40 63 80		
14	Operation	Manual Electric	MA MO		
15	Number of pole	1 pole 2 poles	1 2		
16	Control voltage for electric operation and optional electromagnet locks (Manual operation and without electromagnet lock) Not applicable	24 V _{DC} 48 V _{DC} 60/64 V _{DC} 110 V _{DC} 125 V _{DC} 127 V _{AC} - 50/60 Hz 220 V _{DC} 230 V _{AC} - 50/60 Hz	Z A C G E R X J T		
17	Locking of moving contacts ⁽³⁾	No One key lock locking the open position One key lock locking both positions One electromagnet locking both positions Padlock system with up to 6 padlocks locking in the open position For other selection, refer to the codification table on page 11	∅ B C I Q ...		
18	Cylinder and key delivery	(If no key lock selected in line 17) Not applicable Delivered with random codification For specific code, device will be delivered without cylinder and key, these should be ordered to RONIS supplier	Z 6 1		

⁽¹⁾ Available in version SWI(N)18.40, SWI(N)18.20, SWI(N)18.63 (not available yet, For any need please contact Sécheron).

⁽²⁾ The selection of the appropriate current rating is function of the load cycle. Check with Sécheron that your selection is consistent with the application load cycle. Please refer to overload capacity table page 5.

⁽³⁾ For manual devices, all positions not locked with lock or EMAG will be locked by manual locking lever.



Sécheron SA
 Rue du Pré-Bouvier 25
 1242 Satigny - Geneva
 CH-Switzerland

www.secheron.com
 Tel: +41 22 739 41 11
 Fax: +41 22 739 48 11
ess@secheron.com

Signature:

Name:

Place and date:

SP1880098BEN_E03-05.24